

Main Index

IMPORTANT NOTE:

The Visoglide Plus Upgraded sections and accessories shown in this manual share details with the existing Visoglide Plus manual.

Any specific fabrication details are highlighted in this manual.

Please use this manual alongside the Visoglide Plus manual.

Main Index

VG+ Index	Index	A01 - A02
	Updates.....	A03

A VG+	Profiles	
	Technical Information.....	A05 - A07
	Scale Profile Drawings.....	A08 - A14

B VG+	Accessories	
	Photos & Drawings.....	B03 - B12

C VG+	Sections	
	Slide - Scale Elevations.....	C03 - C38

D VG+	Statics	D03 - D02
--------------	----------------------	-----------

E VG+	Construction Drawings	
	Punch Tool Details.....	E03 - E04
	Drainage Details.....	E05 - E08
	Head Extension Fitting Details.....	E09
	Interlock Plug Details.....	E10
	Slim Interlock Preparation.....	E11 - E12
	Glazing Options.....	E13 - E14

F VG+	Sawing Tables	
	Sliding Doors.....	F03 - F06

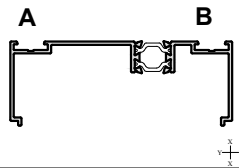
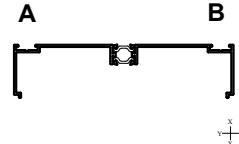
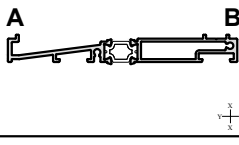
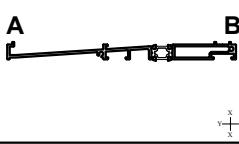
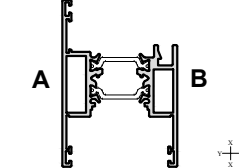
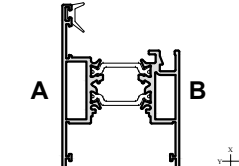
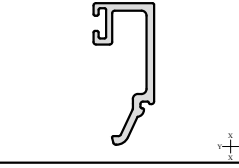
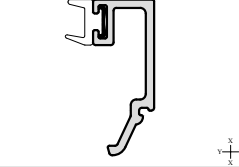
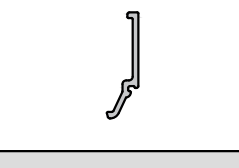
Updates

DATE

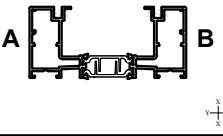
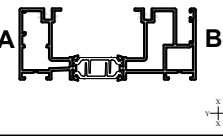

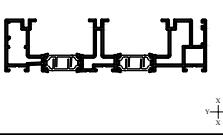
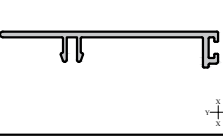
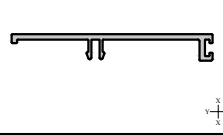
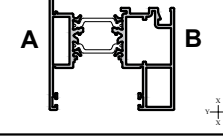
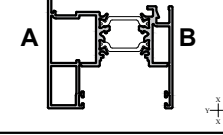
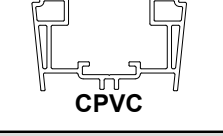
PAGE

DESCRIPTION

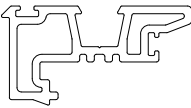


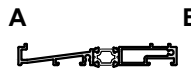



PROFILES : TECHNICAL INFORMATION

Number	Picture	Page	Perim. mm	Mec. mm	Ix(cm4) wx(cm3)	Iy(cm4) wy(cm3)	Length	Pack pr.	MF	SA	KL	HP	M	
VG572		A13	531	85	88.08 ----- 16.34	8.05 ----- 2.42	7	1	✓	✓	✓	✓	✓	
VG573		A14	631	85	247.35 ----- 26.86	9.08 ----- 2.59	6.5	1	✓	✓	✓	✓	✓	
VG578		A12	366	25	56.01 ----- 8.91	0.66 ----- 0.94	6.5	1	✓	✓	✓	✓	✓	
VG584		A12	522	25	182.64 ----- 18.10	0.75 ----- 1.04	6.5	1	✓	✓	✓	✓	✓	
VG920		A10	457	142	20.80 ----- 7.70	13.70 ----- 3.91	6.5	1	✓	✓	✓	✓	✓	
VG920G		A10	461.4	145.5	20.8 ----- 7.7	13.7 ----- 3.91	6.5	1	✓	✓	✓	✓	✓	
VG960		A10	111	33	- ----- -	- ----- -	6.5	1	✓	✓	✓	✓		
VG960G		A10	108.8	35.6	- ----- -	- ----- -	6.5	1	✓	✓	✓	✓		
VG964		A11	109	25	- ----- -	- ----- -	6.5	1	✓	✓	✓	✓		
									A = Outside B = Inside		MF = Mill Finish SA = Silver Anodised KL = Basic Colour HP = Special Colour M = Dual Colour			

PROFILES : TECHNICAL INFORMATION

Number	Picture	Page	Perim. mm	Mec. mm	Ix(cm4) wx(cm3)	Iy(cm4) wy(cm3)	Length	Pack pr.	MF	SA	KL	HP	M	
VG5010		A08	502	141	102.64 — 19.59	17.94 — 8.19	6.5	1	✓	✓	✓	✓	✓	
VG5011		A08	591	221	144.99 — 23.57	19.9 — 8.96	6.5	1	✓	✓	✓	✓	✓	
VG5012		A09	632	154	359.66 — 41.97	25.66 — 12.34	6.5	1	✓	✓	✓	✓	✓	
VG5013		A09	720	234	461.92 — 48.37	27.47 — 12.96	6.5	1	✓	✓	✓	✓	✓	
VG5014		A08	167	59	3.67 — 1.16	0.07 — 0.33	6.5	1	✓	✓	✓	✓		
VG5015		A09	186	67	6.28 — 1.74	0.07 — 0.37	6.5	1	✓	✓	✓	✓		
VG5023		A11	449	157	38.01 — 11.28	19.87 — 6.02	6.5	1	✓	✓	✓	✓	✓	
VG5024		A11	495	157	36.95 — 10.50	19.02 — 5.80	6.5	1	✓	✓	✓	✓	✓	
VG5050		A08	293	-	- ----- -	- ----- -	7.0	1	✓					
									A = Outside B = Inside		MF = Mill Finish SA = Silver Anodised KL = Basic Colour HP = Special Colour M = Dual Colour			

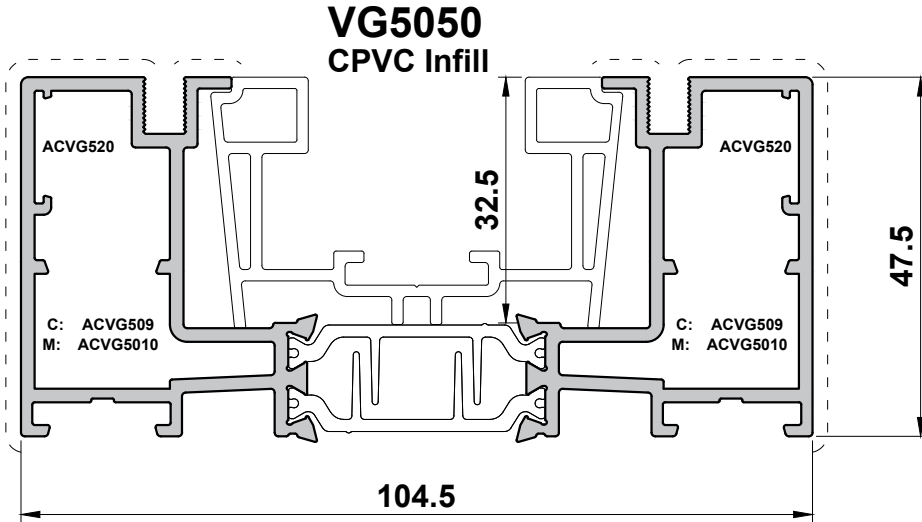
PROFILES : TECHNICAL INFORMATION

Number	Picture	Page	Perim. mm	Mec. mm	Ix(cm4) wx(cm3)	Iy(cm4) wy(cm3)	Length	Pack pr.	MF	SA	KL	HP	M
VG5051	 Polyamide	A10	293	-	- ----- -	- ----- -	6.5	1	✓				
VG5058	 A B	A13	475	85	66.40 — 12.70	7.06 — 5.39	6.5	1	✓	✓	✓	✓	✓
VG5059	 A B	A14	632	85	66.40 — 12.70	7.06 — 5.39	6.5	1	✓	✓	✓	✓	✓
VG5077	 A B	A12	337	25	40.74 — 7.24	0.55 — 0.77	6.5	1	✓	✓	✓	✓	✓
VG5079	 A B	A12	493	25	149.44 — 15.86	0.64 — 0.84	6.5	1	✓	✓	✓	✓	✓
VG7075	 PVC	A10	118	-	- ----- -	- ----- -	6.5	1	✓				
PCX47	 PVC	A10	43	-	- ----- -	- ----- -	6.5	1	✓				
									A = Outside B = Inside	MF = Mill Finish SA = Silver Anodised KL = Basic Colour HP = Special Colour M = Dual Colour			

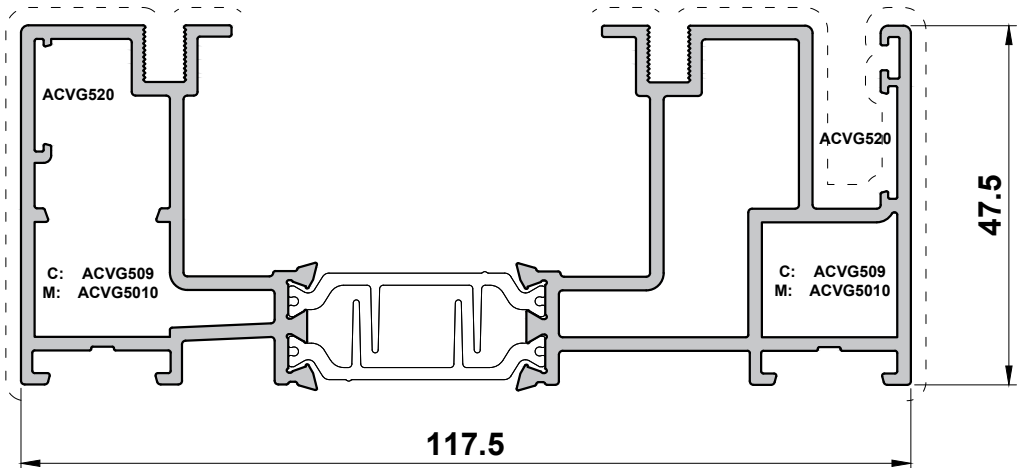
Primary Visible Side

Secondary Visible Side

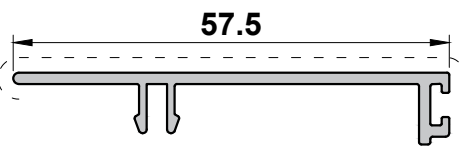
VG5010
Two Track
Outer Frame



VG5011
Two Track
Outer Frame
with Upstand



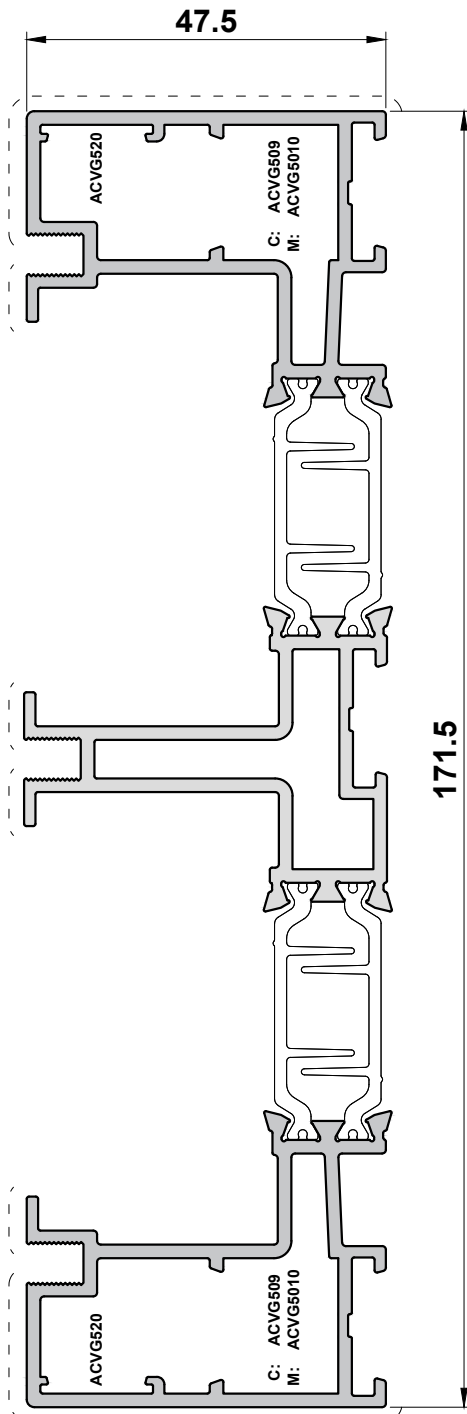
VG5014
Two Track Cover



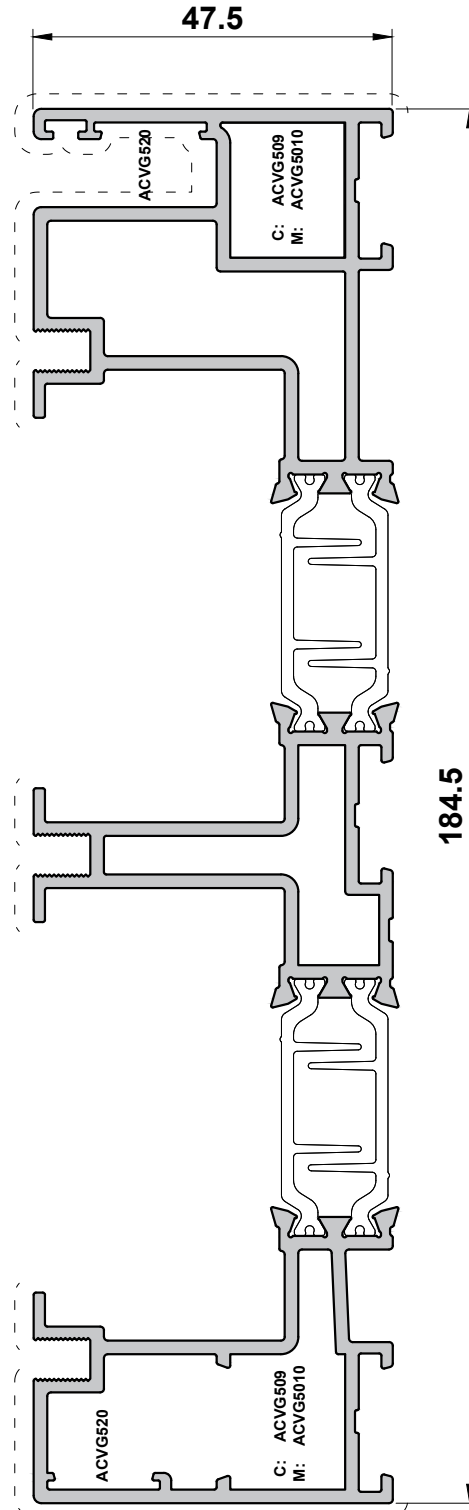
Primary Visible Side

Secondary Visible Side

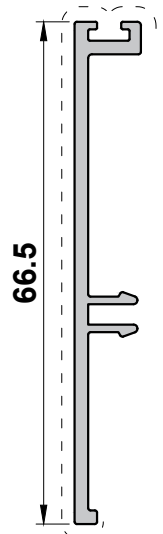
VG5012
Three Track
Outer Frame



VG5013
Three Track
Outer Frame with Upstand



VG5015
Three Track
Cover

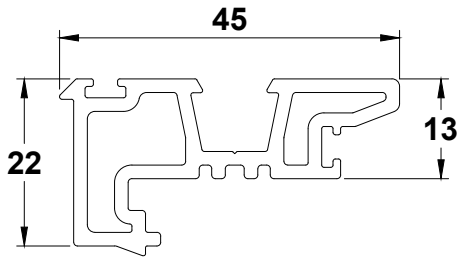


Scale 1:1

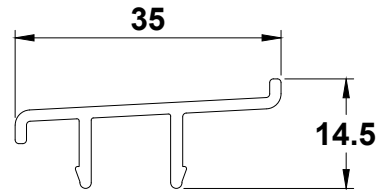
Primary Visible Side

Secondary Visible Side

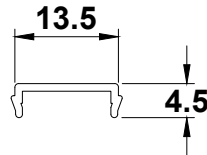
VG5051
Polyamide Interlock



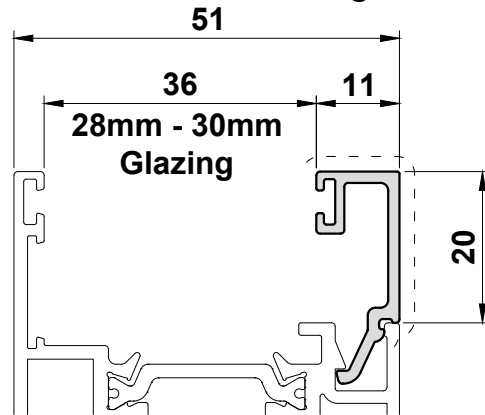
VG7075
PVC Cill Infill



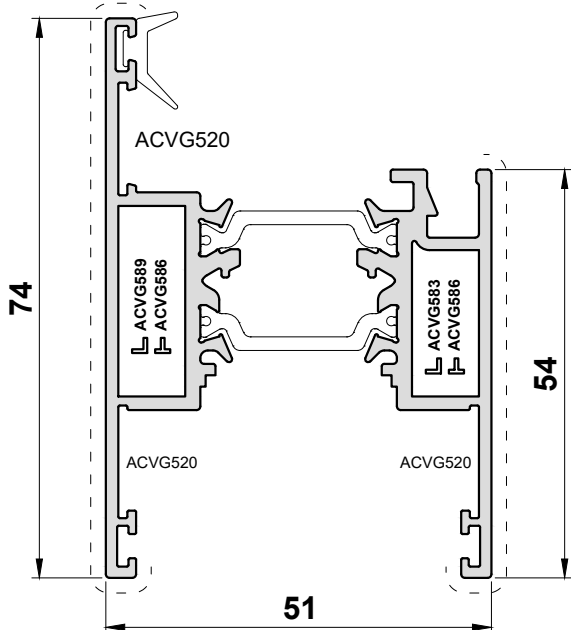
PCX47
PVC Infill



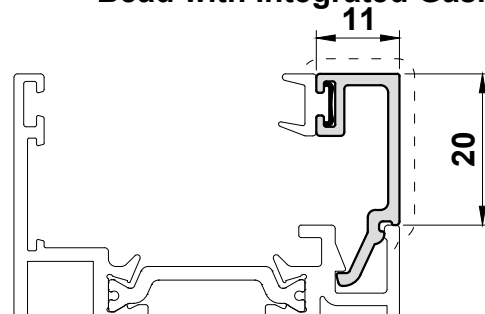
VG960
Glazing Bead



VG920 & VG920G*
Quick Glaze Sash
*Integrated Gasket



VG960G
Bead with Integrated Gasket

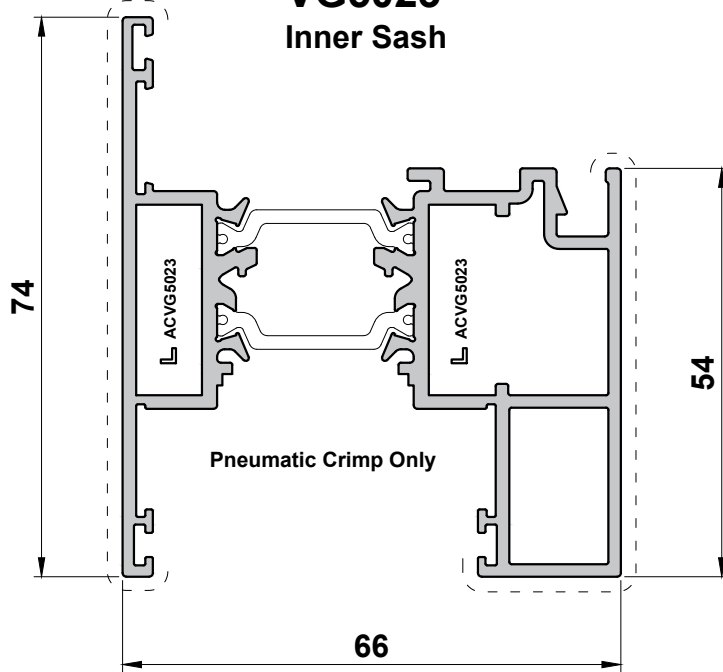


Scale 1:1

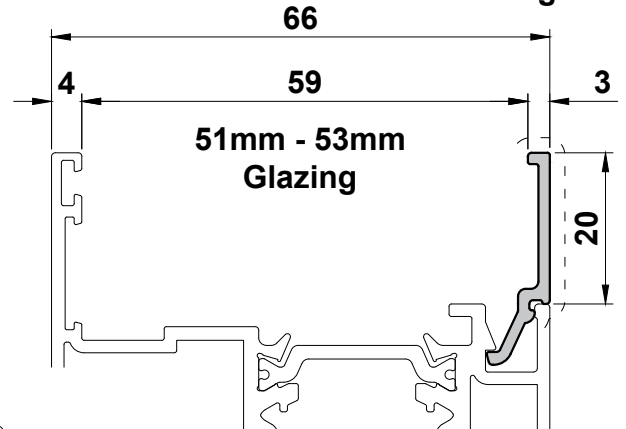
Primary Visible Side

Secondary Visible Side

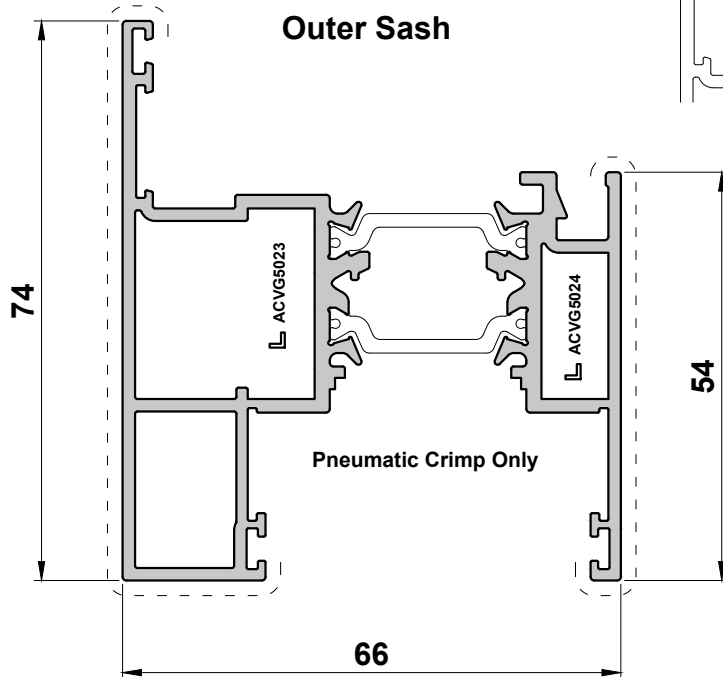
VG5023
Inner Sash



VG964
Glazing Bead



VG5024
Outer Sash



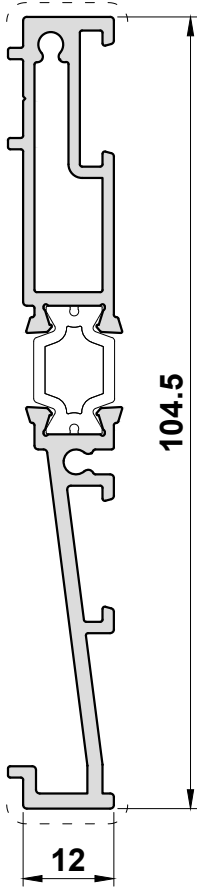
Scale 1:1

Primary Visible Side

Secondary Visible Side

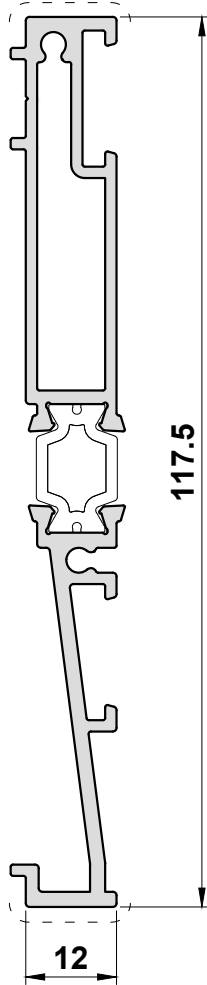
VG5077
Drainage Tray

End Cap:
ACVG5077



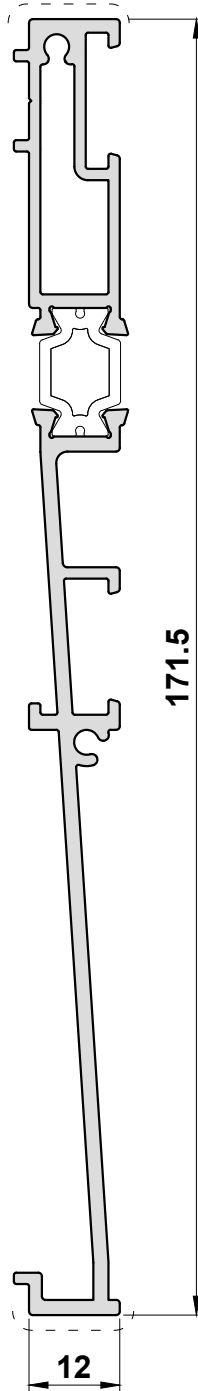
VG578
Drainage Tray

End Cap:
ACVG578



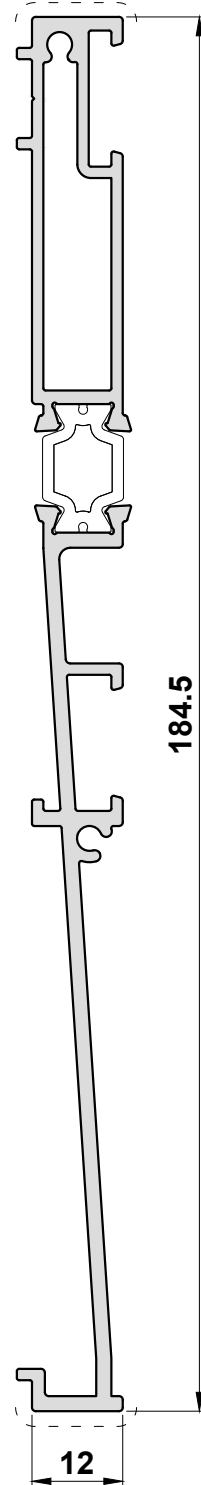
VG5079
Drainage Tray

End Cap:
ACVG5079



VG584
Drainage Tray

End Cap:
ACVG584

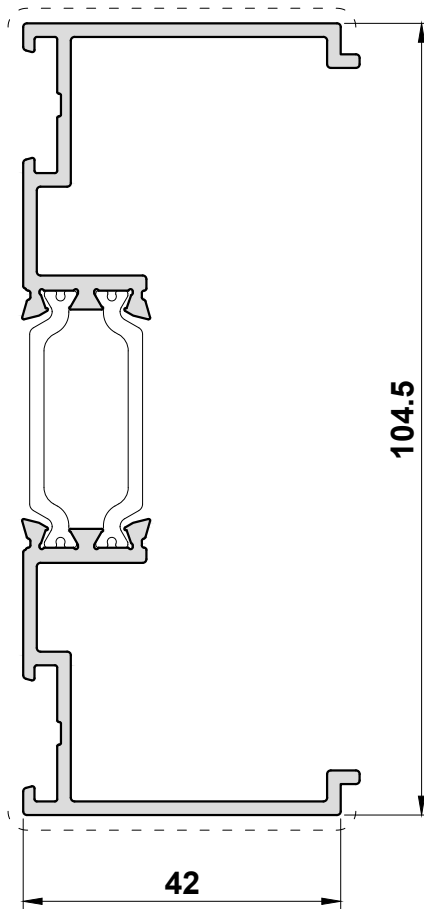


Scale 1:1

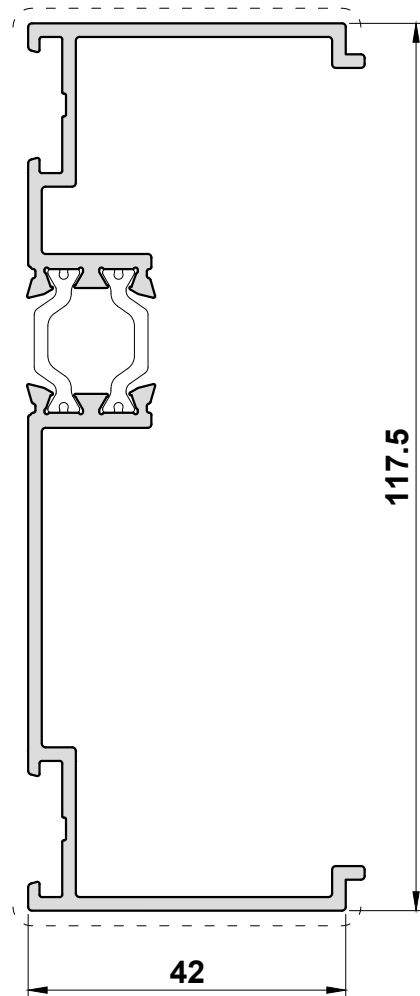
Primary Visible Side

Secondary Visible Side

VG5058
VG5010 Two Track
Head Extension



VG572
VG5011 Track
Head Extension



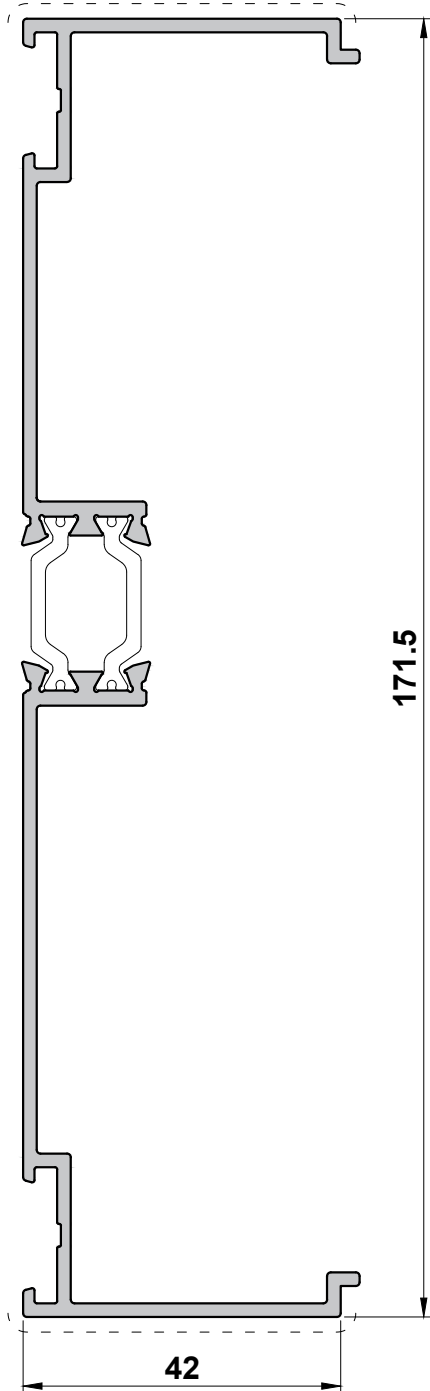
Scale 1:1

Primary Visible Side

Secondary Visible Side

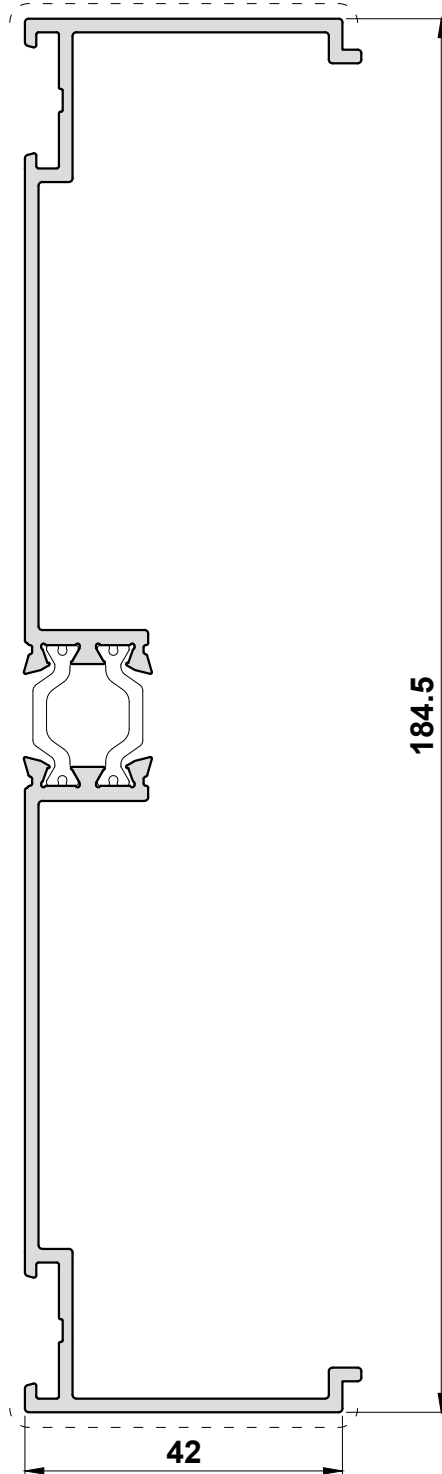
VG5059

VG5012 Three Track
Head Extension



VG573

VG5013 Three Track
Head Extension



Scale 1:1

Section B

Accessories

Photos & Drawings

IMPORTANT NOTE:

The Visoglide Plus Upgraded sections and accessories shown in this manual share details with the existing Visoglide Plus manual.

Any specific fabrication details are highlighted in this manual.

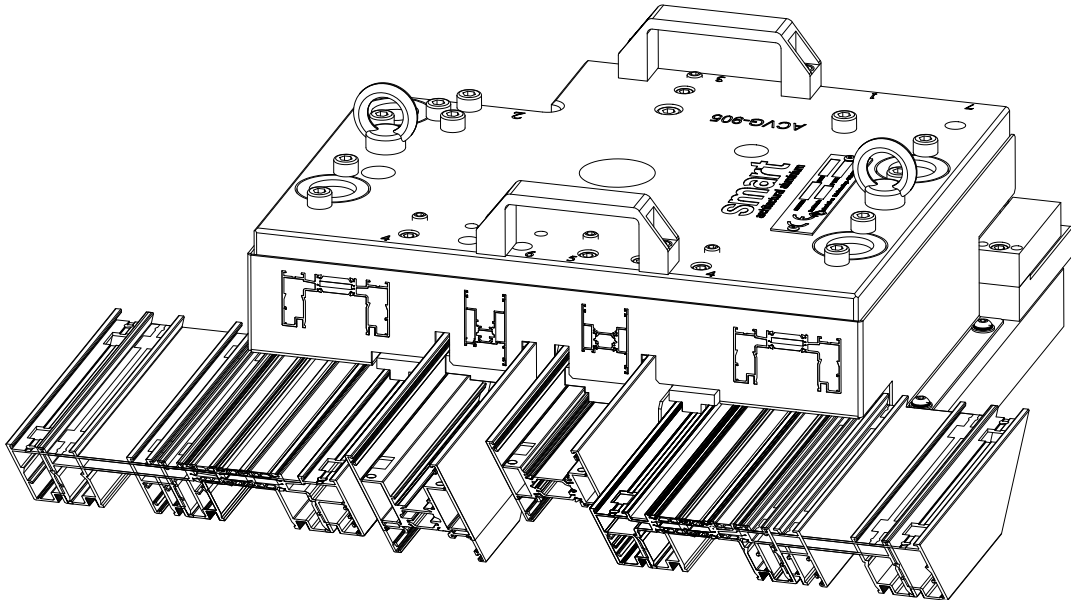
Please use this manual alongside the Visoglide Plus manual.

Section B

Punch Tool

Part Number : ACVG905N

for application refer to page E03

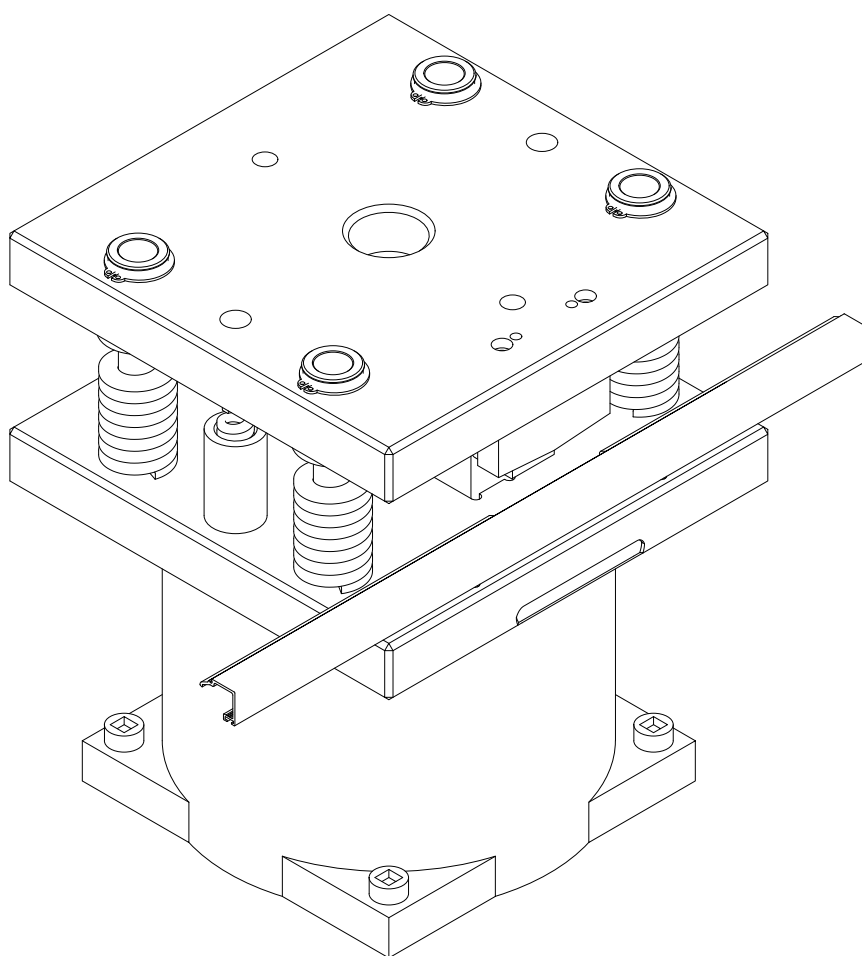


ACVG905 has been modified to accept VG920

Punch Tool








Part Number : ACDV916

for application refer to page E04



Retaining Gasket









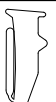

Commonly known as an E Gasket.
Retaining gaskets create a seal between the Glass and the Aluminium Profile.

High Line	2mm		ACVG231		
			200m	BL	
3mm	3mm		ACVG31		
			200m	BL	
4mm	4mm		ACVG131		
			100m	BL	
Low Line	2mm		ACET844		
			200m	BL	
			BL		
	3mm	3mm		ACET842	
				200m	BL
	4mm	4mm		ACET841	
				200m	BL
	4mm	4mm		ACET835	
				200m	BL

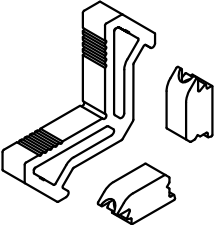
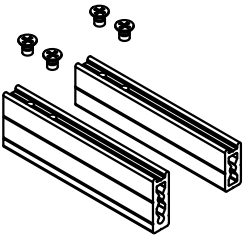
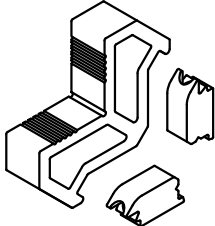
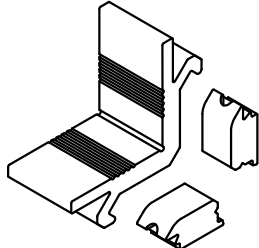
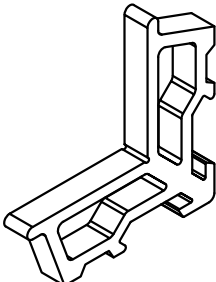


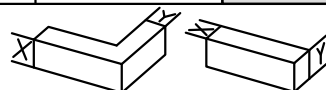
Thickness	Drawing 1:1	Part number
		Coil length
		Available Colours

Wedge Gasket

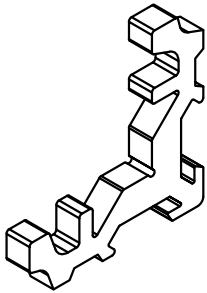
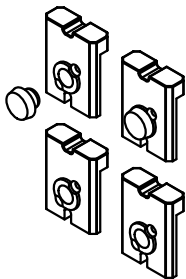
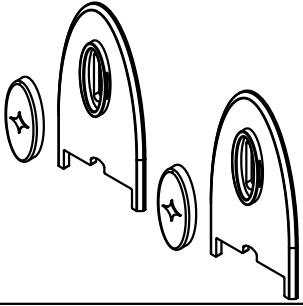
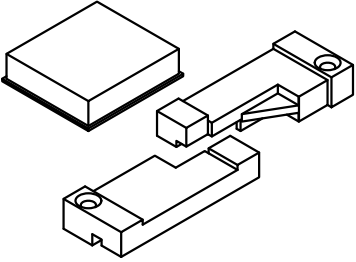
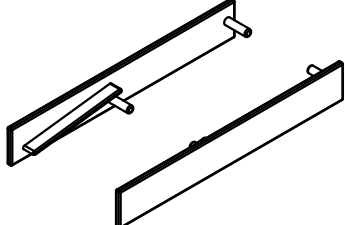


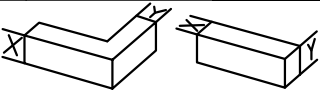
Wedge Gaskets help to hold the bead in place by providing tension between the bead and the glazing unit.

High Line	3mm		ACVG32	
			100m	BL
			BL	
3mm	3mm		ACVG32N	
			100m	BL
4mm	4mm		ACVG33	
			100m	BL
4mm	4mm		ACVG33N	
			100m	BL
			BL	
5mm	5mm		ACVG34	
			100m	BL
5mm	5mm		ACVG34N	
			100m	BL
6mm	6mm		ACVG340	
			200m	BL
6mm	6mm		ACVG340N	
			100m	BL
Low Line	4mm - 3mm		ACW20038	
			50m	BL
	5mm - 4mm	4mm - 3mm		ACET848
200m				BL

ACCESSORIES : PHOTOS & DRAWINGS

Image	Part Code	Pack	Unit	Application	Colour
	ACVG583 Mechanical Cleat	24	pack	VG920 VG5024	MF <input checked="" type="checkbox"/>
					SA <input type="checkbox"/>
					KL <input type="checkbox"/>
					HP <input type="checkbox"/>
					SSC <input type="checkbox"/>
					SMC <input type="checkbox"/>
					W <input type="checkbox"/>
					Z <input type="checkbox"/>
					PC <input type="checkbox"/>
	ACVG586 Slim Interlock Fixing Bracket	8	pack	VG920 VG535 VG536 VG539 VG590 VG592	MF <input checked="" type="checkbox"/>
					SA <input type="checkbox"/>
					KL <input type="checkbox"/>
					HP <input type="checkbox"/>
					SSC <input type="checkbox"/>
					SMC <input type="checkbox"/>
					W <input type="checkbox"/>
					Z <input type="checkbox"/>
					PC <input type="checkbox"/>
	ACVG589 Mechanical Cleat	24	pack	VG520 VG920 VG5023 VG5024	MF <input checked="" type="checkbox"/>
					SA <input type="checkbox"/>
					KL <input type="checkbox"/>
					HP <input type="checkbox"/>
					SSC <input type="checkbox"/>
					SMC <input type="checkbox"/>
					W <input type="checkbox"/>
					Z <input type="checkbox"/>
					PC <input type="checkbox"/>
	ACVG5010 Mechanical Cleat	24	pack	VG5010 VG5011 VG5012 VG5013	MF <input checked="" type="checkbox"/>
					SA <input type="checkbox"/>
					KL <input type="checkbox"/>
					HP <input type="checkbox"/>
					SSC <input type="checkbox"/>
					SMC <input type="checkbox"/>
					W <input type="checkbox"/>
					Z <input type="checkbox"/>
					PC <input type="checkbox"/>
	ACVG5023 Crimping Cleat Pneumatic Crimp Only	24	pack	VG5023 VG5024	MF <input checked="" type="checkbox"/>
					SA <input type="checkbox"/>
					KL <input type="checkbox"/>
					HP <input type="checkbox"/>
					SSC <input type="checkbox"/>
					SMC <input type="checkbox"/>
					W <input type="checkbox"/>
					Z <input type="checkbox"/>
					PC <input type="checkbox"/>
 <p>T-BARS ACVG65=2.5mm ACVG66=3.0mm ACVL150=4.0mm</p>  <p>Screw (Grub)</p>	MF = Mill Finish SA = Silver Anodised KL = Basic Colour HP = Special Colour SSC = Smooth Satin Chrome SMC = Smokey Chrome PC = Polished Chrome	W = White Z = Black			

ACCESSORIES : PHOTOS & DRAWINGS

Image	Part Code	Pack	Unit	Application	Colour
	ACVG5024 Crimping Cleat Pneumatic Crimp Only	24	pack	VG5024	MF <input checked="" type="checkbox"/>
					SA <input type="checkbox"/>
					KL <input type="checkbox"/>
					HP <input type="checkbox"/>
					SSC <input type="checkbox"/>
					SMC <input type="checkbox"/>
					W <input type="checkbox"/>
					Z <input type="checkbox"/>
					PC <input type="checkbox"/>
	ACVG5029 Anti-Lift & Buffer	1	Kit	VG920	MF <input type="checkbox"/>
					SA <input type="checkbox"/>
					KL <input type="checkbox"/>
					HP <input type="checkbox"/>
					SSC <input type="checkbox"/>
					SMC <input type="checkbox"/>
					W <input type="checkbox"/>
					Z <input checked="" type="checkbox"/>
					PC <input type="checkbox"/>
	ACVG5030 Interlock Cover Caps	1	Kit	VG530	MF <input type="checkbox"/>
					SA <input type="checkbox"/>
					KL <input type="checkbox"/>
					HP <input type="checkbox"/>
					SSC <input type="checkbox"/>
					SMC <input type="checkbox"/>
					W <input type="checkbox"/>
					Z <input checked="" type="checkbox"/>
					PC <input type="checkbox"/>
	ACVG5032 Interlock Plug	2	Kit	VG5010 VG5011 VG5012 VG5013	MF <input type="checkbox"/>
					SA <input type="checkbox"/>
					KL <input type="checkbox"/>
					HP <input type="checkbox"/>
					SSC <input type="checkbox"/>
					SMC <input type="checkbox"/>
					W <input type="checkbox"/>
					Z <input checked="" type="checkbox"/>
					PC <input type="checkbox"/>
	ACVG5077 VG5077 End Caps	10	Pairs	VG5077	MF <input type="checkbox"/>
					SA <input type="checkbox"/>
					KL <input type="checkbox"/>
					HP <input type="checkbox"/>
					SSC <input type="checkbox"/>
					SMC <input type="checkbox"/>
					W <input type="checkbox"/>
					Z <input checked="" type="checkbox"/>
					PC <input type="checkbox"/>
 <small>T-BARS ACVG65=2.5mm ACVG66=3.0mm ACVL150=4.0mm</small>	 <small>Screw (Grub)</small>	MF = Mill Finish SA = Silver Anodised KL = Basic Colour HP = Special Colour SSC = Smooth Satin Chrome SMC = Smokey Chrome PC = Polished Chrome	W = White Z = Black		

ACCESSORIES : PHOTOS & DRAWINGS

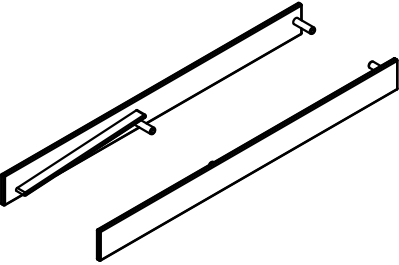
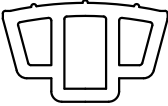
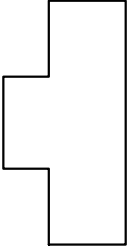


Image	Part Code	Pack	Unit	Application	Colour	
	ACVG5079 VG5079 End Caps	10	Pairs	VG5079	MF	
					SA	
					KL	
					HP	
					SSC	
					SMC	
					W	
					Z	✓
					PC	
						ACVG5070 Insulating Infill
SA						
KL						
HP						
SSC						
SMC						
W						
Z	✓					
PC						
	ACVG5072 Insulating Infill	20	m	VG920		
					SA	
					KL	
					HP	
					SSC	
					SMC	
					W	
					Z	✓
					PC	
SA						
KL						
HP						
SSC						
SMC						
W						
Z						
PC						
 <p>T-BARS ACVG65=2.5mm ACVG66=3.0mm ACVL150=4.0mm</p>  <p>Screw (Grub)</p>	MF = Mill Finish SA = Silver Anodised KL = Basic Colour HP = Special Colour SSC = Smooth Satin Chrome SMC = Smokey Chrome PC = Polished Chrome					
					SA	
					KL	
					HP	
					SSC	
					SMC	
					W	
					Z	
					PC	




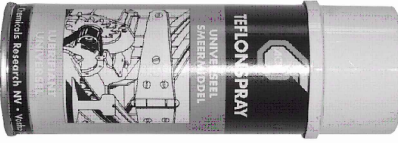



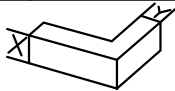
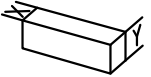
Image	Part Code	Pack	Unit	Application	Colour
	ACMX09700 Alu-Polish Cleaning emulsion for aluminium oxide.	1	each		MF SA KL HP SSC SMC W Z PC
	ACMX09761 Maxi Gloss Protection for painted and anodised surfaces.	1	each		MF SA KL HP SSC SMC W Z PC
	ACMX09762 Alu. Bright Cleaner for rough, anodised or enamelled aluminium frames.	1	each		MF SA KL HP SSC SMC W Z PC
	ACMX09763 Teflon Spray Lubricant	1	each		MF SA KL HP SSC SMC W Z PC
	ACMX09764 Maxi Cleaner For cleaning oily surfaces.	1	each		MF SA KL HP SSC SMC W Z PC
 <p>T-BARS ACVG65=2.5mm ACVG66=3.0mm ACVL150=4.0mm</p>  <p>Screw (Grub)</p>	MF = Mill Finish SA = Silver Anodised KL = Basic Colour HP = Special Colour SSC = Smooth Satin Chrome SMC = Smokey Chrome PC = Polished Chrome	W = White Z = Black		 	

Image	Part Code	Pack	Unit	Application	Colour
	ACMX09765 Glue Cleaner De-grease and silicone remover.	1	each		MF SA KL HP SSC SMC W Z PC
	ACMX09770 Roll & Wrap 100mm	1	each		MF SA KL HP SSC SMC W Z PC
	ACMX09775 Grip Handwrap	1	each		MF SA KL HP SSC SMC W Z PC
	ACMX09801 Protective Tape 50mm	1	each		MF SA KL HP SSC SMC W Z PC
	ACMX09802 Protective Tape 70mm	1	each		MF SA KL HP SSC SMC W Z PC
 <p>T-BARS ACVG65=2.5mm ACVG66=3.0mm ACVL150=4.0mm</p>  <p>Screw (Grub)</p>	<p>MF = Mill Finish SA = Silver Anodised KL = Basic Colour HP = Special Colour SSC = Smooth Satin Chrome SMC = Smokey Chrome PC = Polished Chrome</p>	<p>W = White Z = Black</p>			

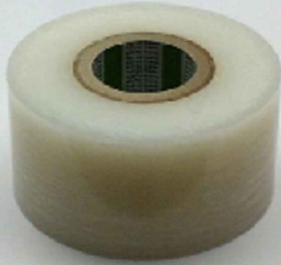






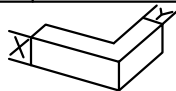
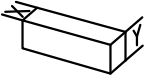



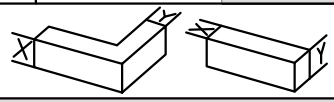
Image	Part Code	Pack	Unit	Application	Colour																		
	ACMX09803 Protective Tape 100mm	1	each		<table border="1"> <tr><td>MF</td><td></td></tr> <tr><td>SA</td><td></td></tr> <tr><td>KL</td><td></td></tr> <tr><td>HP</td><td></td></tr> <tr><td>SSC</td><td></td></tr> <tr><td>SMC</td><td></td></tr> <tr><td>W</td><td></td></tr> <tr><td>Z</td><td></td></tr> <tr><td>PC</td><td></td></tr> </table>	MF		SA		KL		HP		SSC		SMC		W		Z		PC	
MF																							
SA																							
KL																							
HP																							
SSC																							
SMC																							
W																							
Z																							
PC																							
	ACSIL05 Rubber Sealant	1	each		<table border="1"> <tr><td>MF</td><td></td></tr> <tr><td>SA</td><td></td></tr> <tr><td>KL</td><td></td></tr> <tr><td>HP</td><td></td></tr> <tr><td>SSC</td><td></td></tr> <tr><td>SMC</td><td></td></tr> <tr><td>W</td><td></td></tr> <tr><td>Z</td><td></td></tr> <tr><td>PC</td><td></td></tr> </table>	MF		SA		KL		HP		SSC		SMC		W		Z		PC	
MF																							
SA																							
KL																							
HP																							
SSC																							
SMC																							
W																							
Z																							
PC																							
	ACSIL04 Sealing Glue Order with suffix of KL colour (eg.ACSIL04KL005) or BL=Black/WP=White/ CL=Clear	1	each		<table border="1"> <tr><td>MF</td><td></td></tr> <tr><td>SA</td><td></td></tr> <tr><td>KL</td><td>✓</td></tr> <tr><td>HP</td><td></td></tr> <tr><td>SSC</td><td></td></tr> <tr><td>SMC</td><td></td></tr> <tr><td>W</td><td>✓</td></tr> <tr><td>Z</td><td>✓</td></tr> <tr><td>PC</td><td></td></tr> </table>	MF		SA		KL	✓	HP		SSC		SMC		W	✓	Z	✓	PC	
MF																							
SA																							
KL	✓																						
HP																							
SSC																							
SMC																							
W	✓																						
Z	✓																						
PC																							
	ACSIL08 Silicon Gun	1	each		<table border="1"> <tr><td>MF</td><td></td></tr> <tr><td>SA</td><td></td></tr> <tr><td>KL</td><td></td></tr> <tr><td>HP</td><td></td></tr> <tr><td>SSC</td><td></td></tr> <tr><td>SMC</td><td></td></tr> <tr><td>W</td><td></td></tr> <tr><td>Z</td><td></td></tr> <tr><td>PC</td><td></td></tr> </table>	MF		SA		KL		HP		SSC		SMC		W		Z		PC	
MF																							
SA																							
KL																							
HP																							
SSC																							
SMC																							
W																							
Z																							
PC																							
	ACSIL013 Glue for Mitre	1	each		<table border="1"> <tr><td>MF</td><td></td></tr> <tr><td>SA</td><td></td></tr> <tr><td>KL</td><td></td></tr> <tr><td>HP</td><td></td></tr> <tr><td>SSC</td><td></td></tr> <tr><td>SMC</td><td></td></tr> <tr><td>W</td><td></td></tr> <tr><td>Z</td><td></td></tr> <tr><td>PC</td><td></td></tr> </table>	MF		SA		KL		HP		SSC		SMC		W		Z		PC	
MF																							
SA																							
KL																							
HP																							
SSC																							
SMC																							
W																							
Z																							
PC																							
 <p>T-BARS ACVG65=2.5mm ACVG66=3.0mm ACVL150=4.0mm</p>  <p>Screw (Grub)</p>	<p>MF = Mill Finish SA = Silver Anodised KL = Basic Colour HP = Special Colour SSC = Smooth Satin Chrome SMC = Smokey Chrome PC = Polished Chrome</p>	<p>W = White Z = Black</p>	 																				

Image	Part Code	Pack	Unit	Application	Colour	
	ACSIL014 Anti-Corrosion Coating	1	each		MF <input checked="" type="checkbox"/>	
					SA <input type="checkbox"/>	
					KL <input type="checkbox"/>	
					HP <input type="checkbox"/>	
					SSC <input type="checkbox"/>	
					SMC <input type="checkbox"/>	
					W <input type="checkbox"/>	
					Z <input type="checkbox"/>	
					PC <input type="checkbox"/>	
						ACUN3900 Gasket Roller
SA <input type="checkbox"/>						
KL <input type="checkbox"/>						
HP <input type="checkbox"/>						
SSC <input type="checkbox"/>						
SMC <input type="checkbox"/>						
W <input type="checkbox"/>						
Z <input type="checkbox"/>						
PC <input type="checkbox"/>						
					SA <input type="checkbox"/>	
					KL <input type="checkbox"/>	
					HP <input type="checkbox"/>	
					SSC <input type="checkbox"/>	
					SMC <input type="checkbox"/>	
					W <input type="checkbox"/>	
					Z <input type="checkbox"/>	
					PC <input type="checkbox"/>	
SA <input type="checkbox"/>						
KL <input type="checkbox"/>						
HP <input type="checkbox"/>						
SSC <input type="checkbox"/>						
SMC <input type="checkbox"/>						
W <input type="checkbox"/>						
Z <input type="checkbox"/>						
PC <input type="checkbox"/>						
 <p>T-BARS ACVG65=2.5mm ACVG66=3.0mm ACVL150=4.0mm</p> <p>Screw (Grub)</p>	MF = Mill Finish SA = Silver Anodised KL = Basic Colour HP = Special Colour SSC = Smooth Satin Chrome SMC = Smokey Chrome PC = Polished Chrome					
					Z = Black	
						

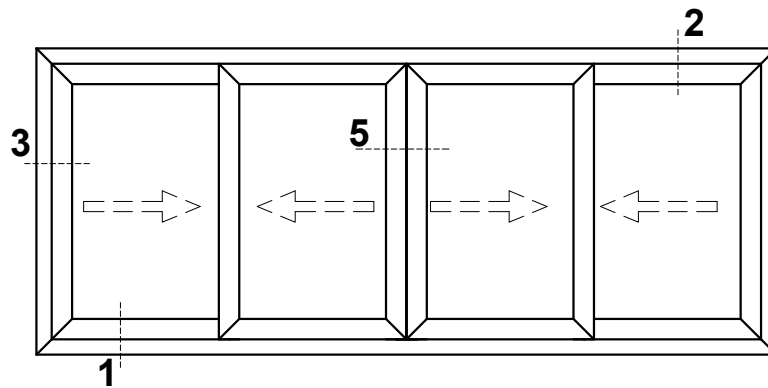
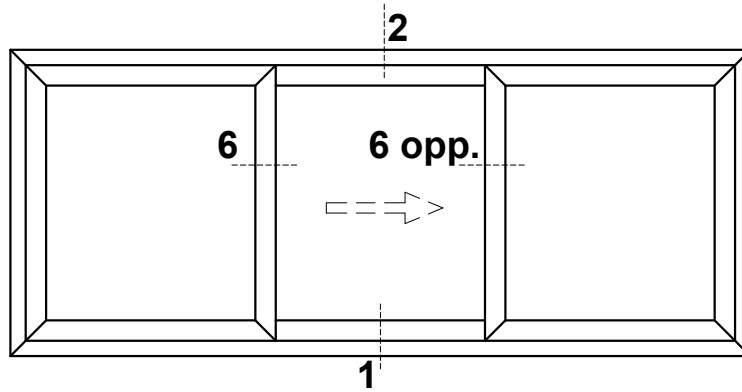
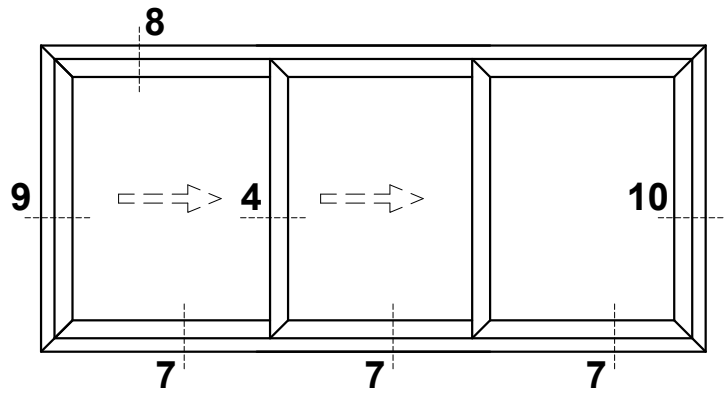
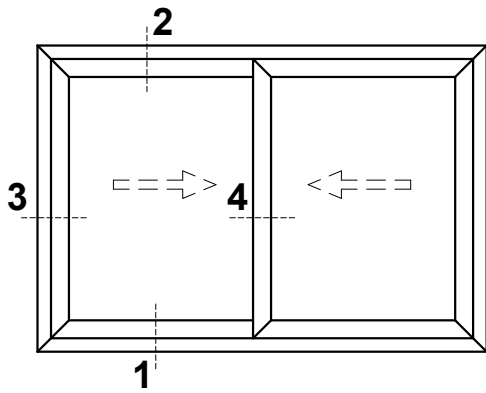
Section C

Sections

Scale Elevations

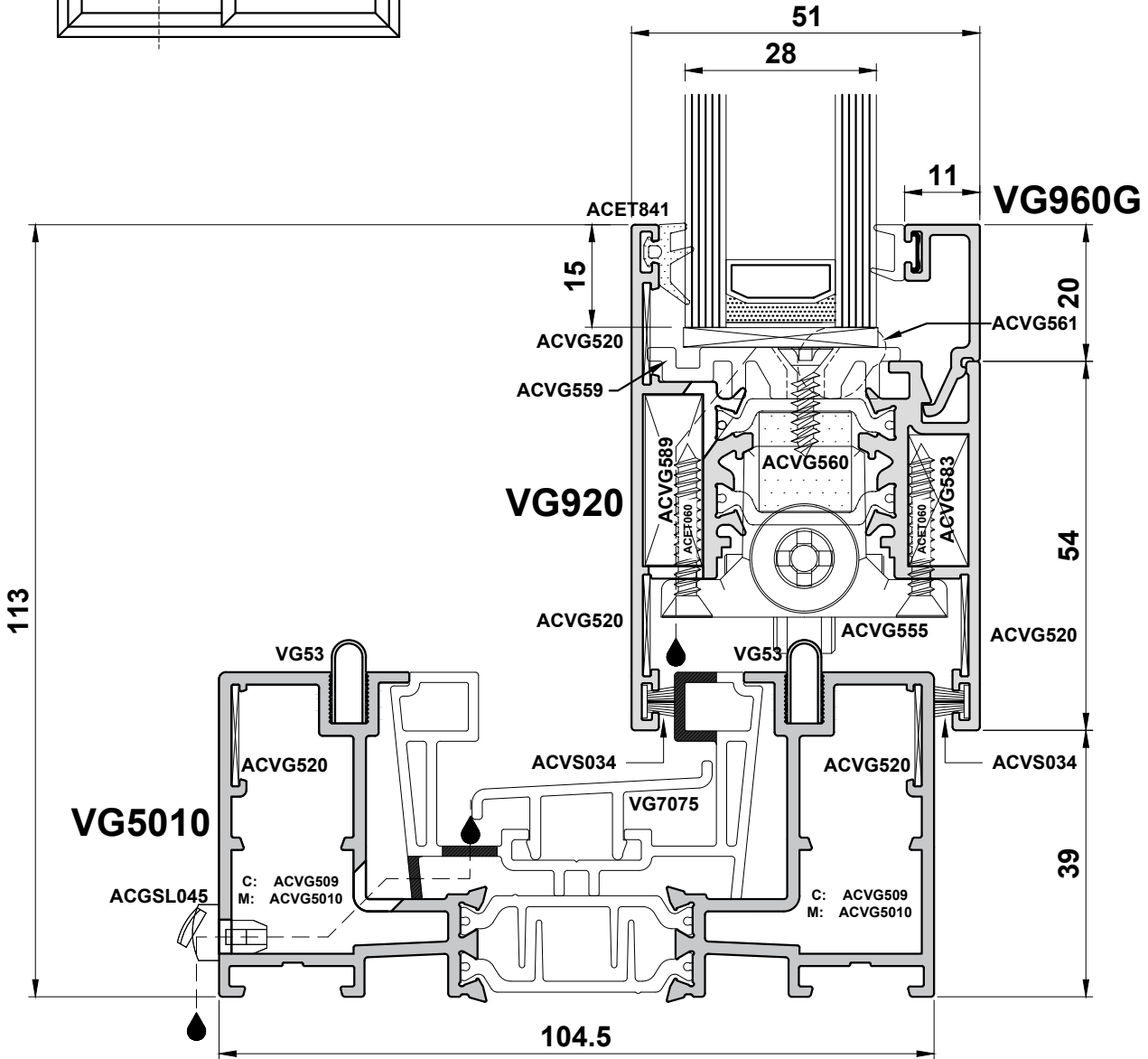
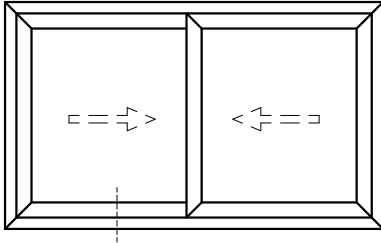
Section C

Scale Elevations



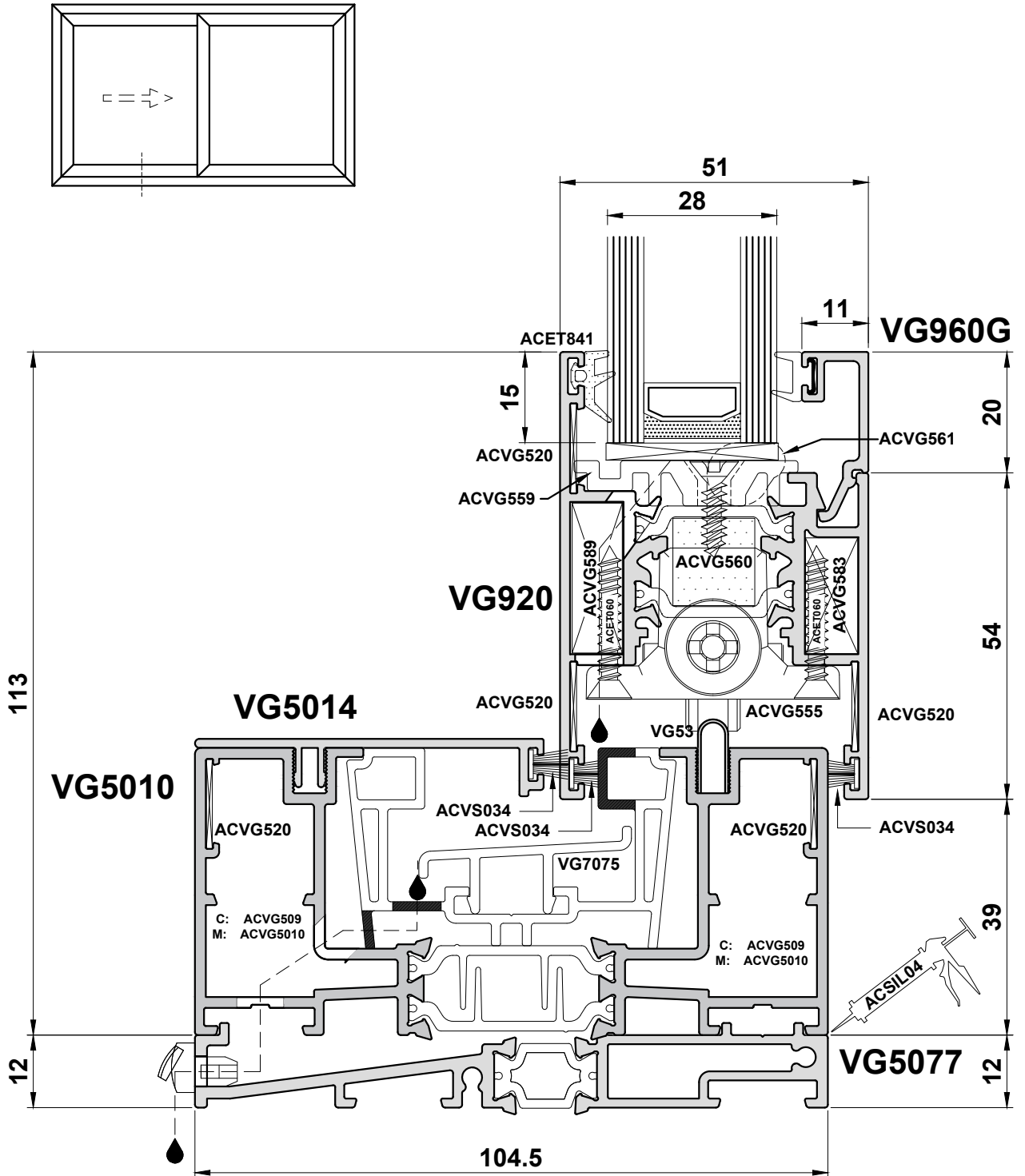
Do Not Scale From This Drawing

Detail 1A



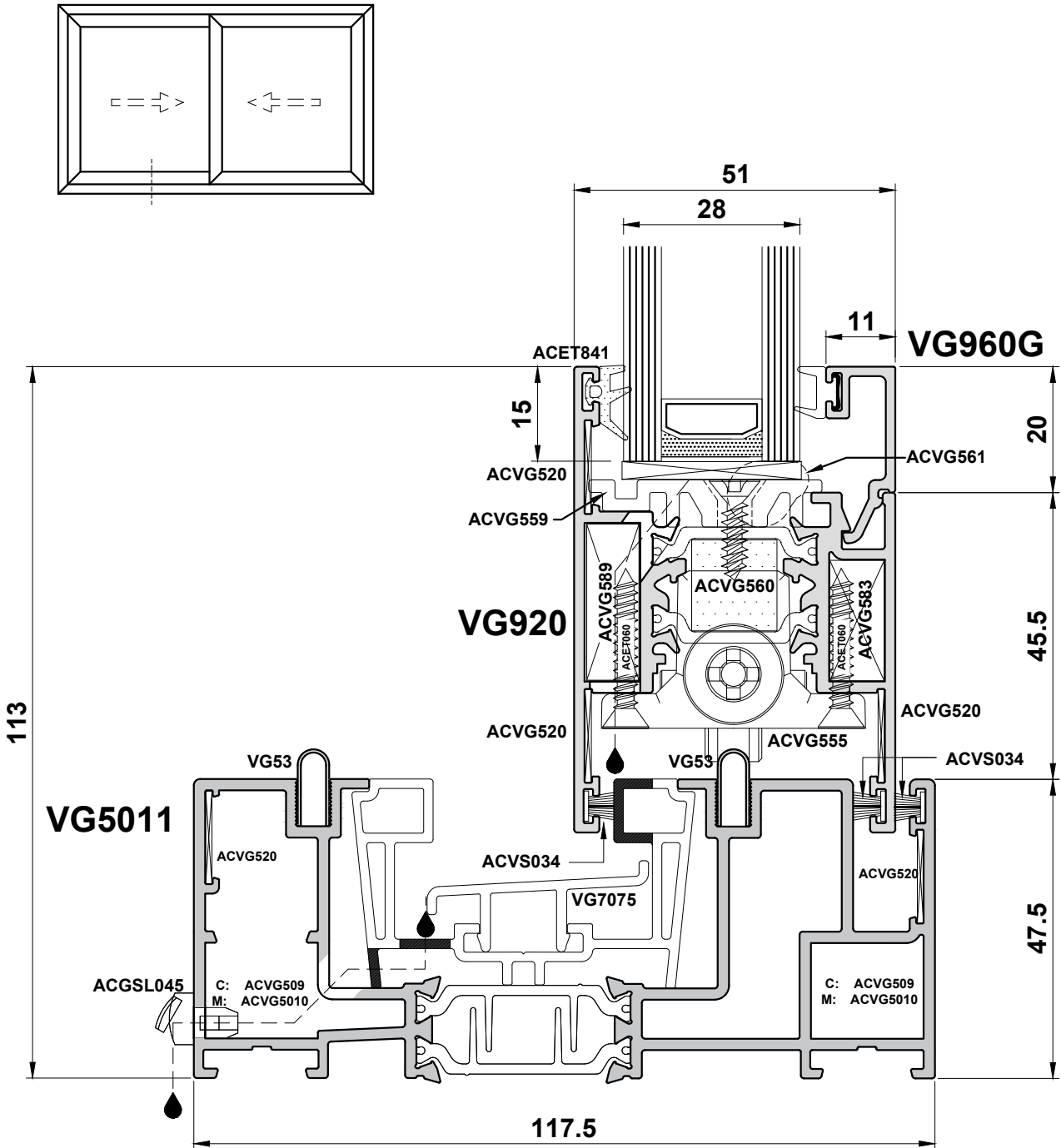
Do Not Scale From This Drawing

Detail 1B



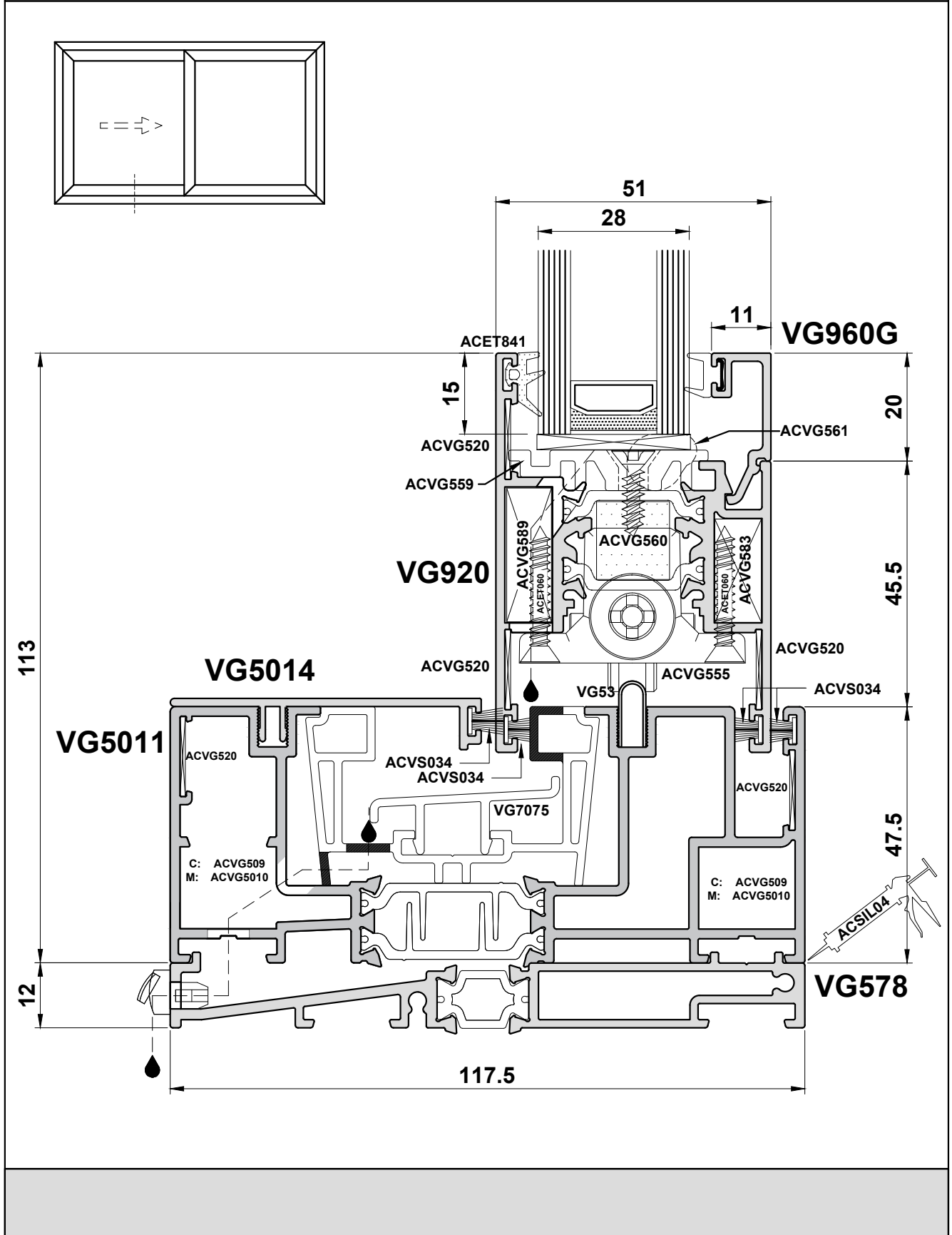
Do Not Scale From This Drawing

Detail 1C

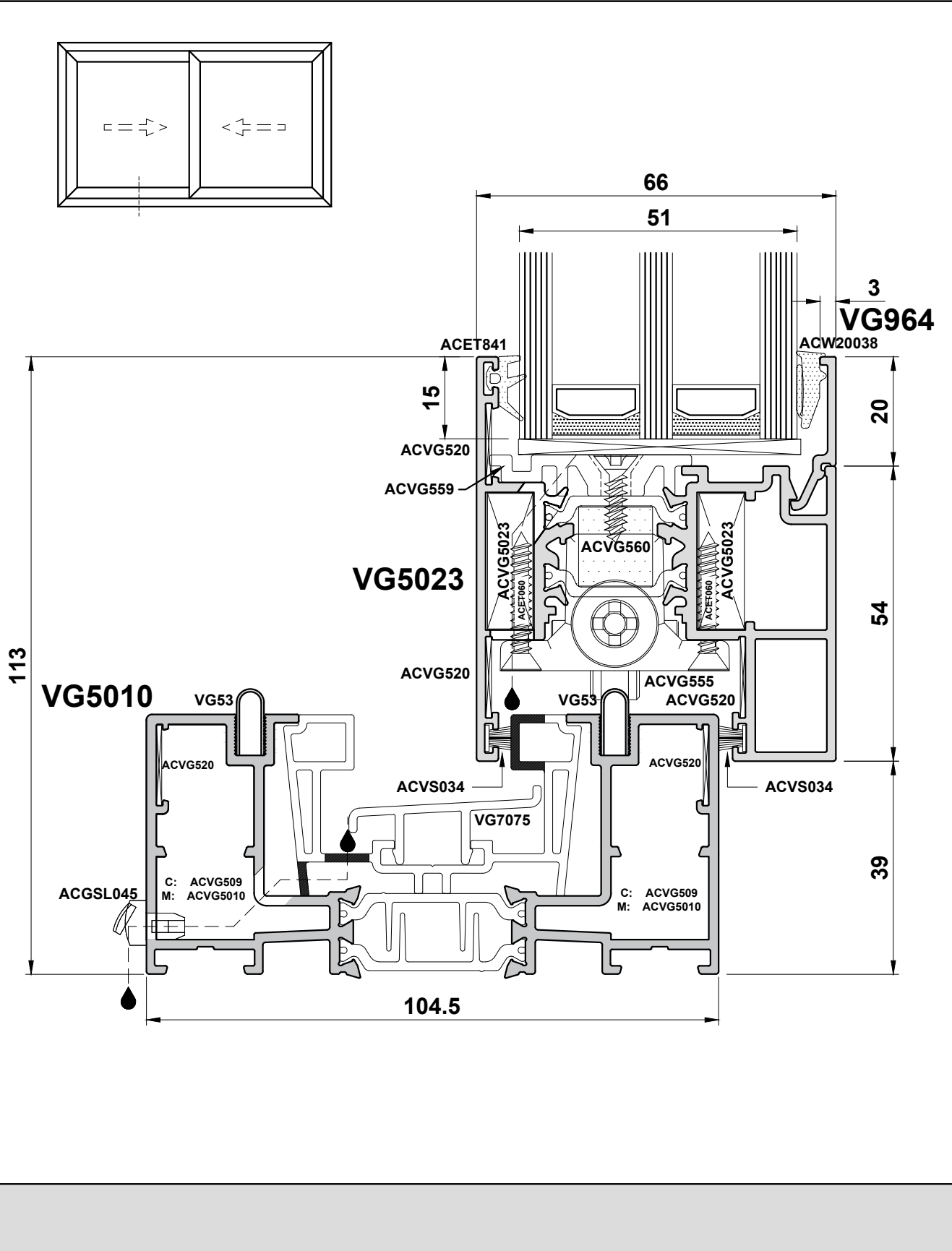


Do Not Scale From This Drawing

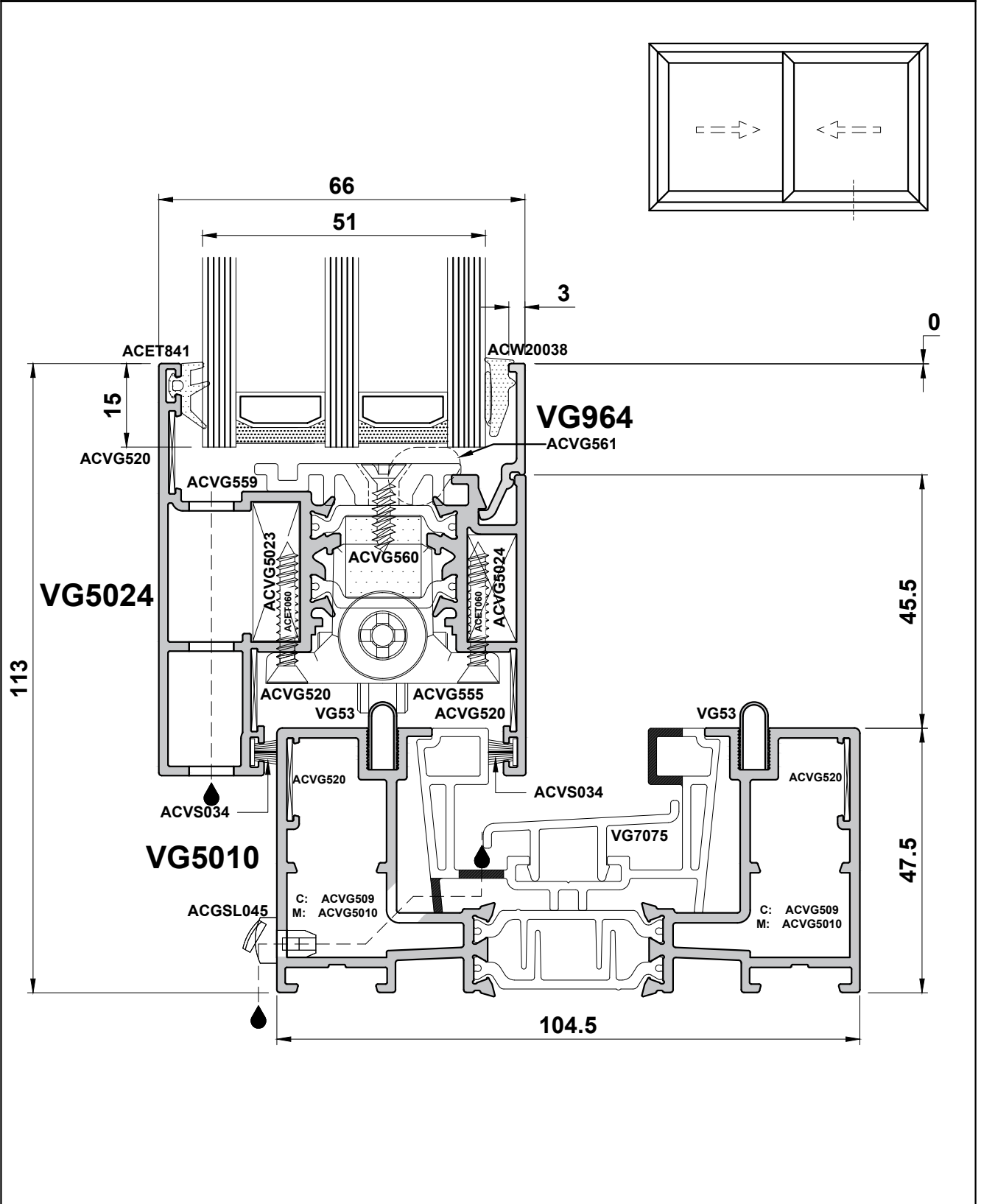
Detail 1D



Detail 1E

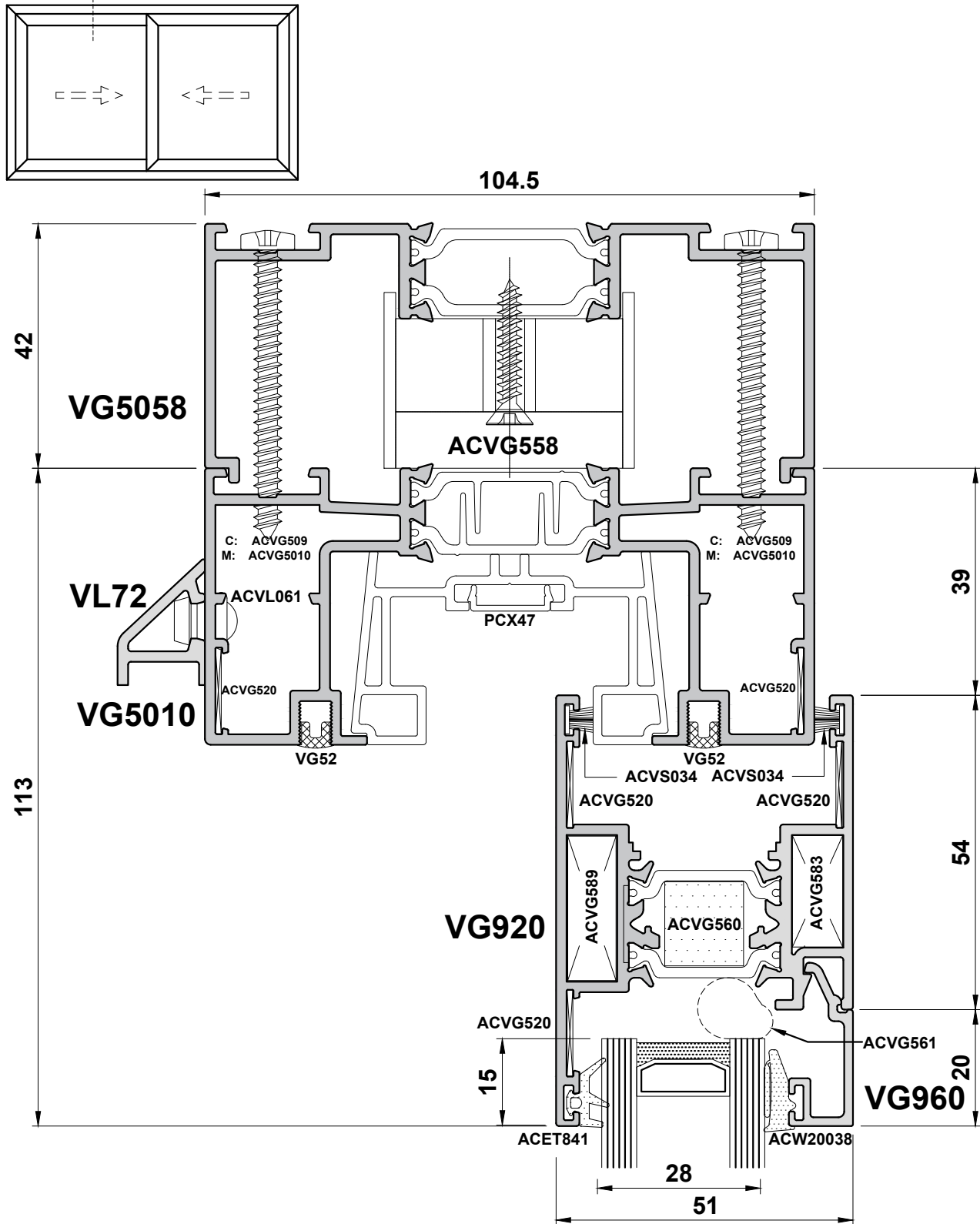


Detail 1F



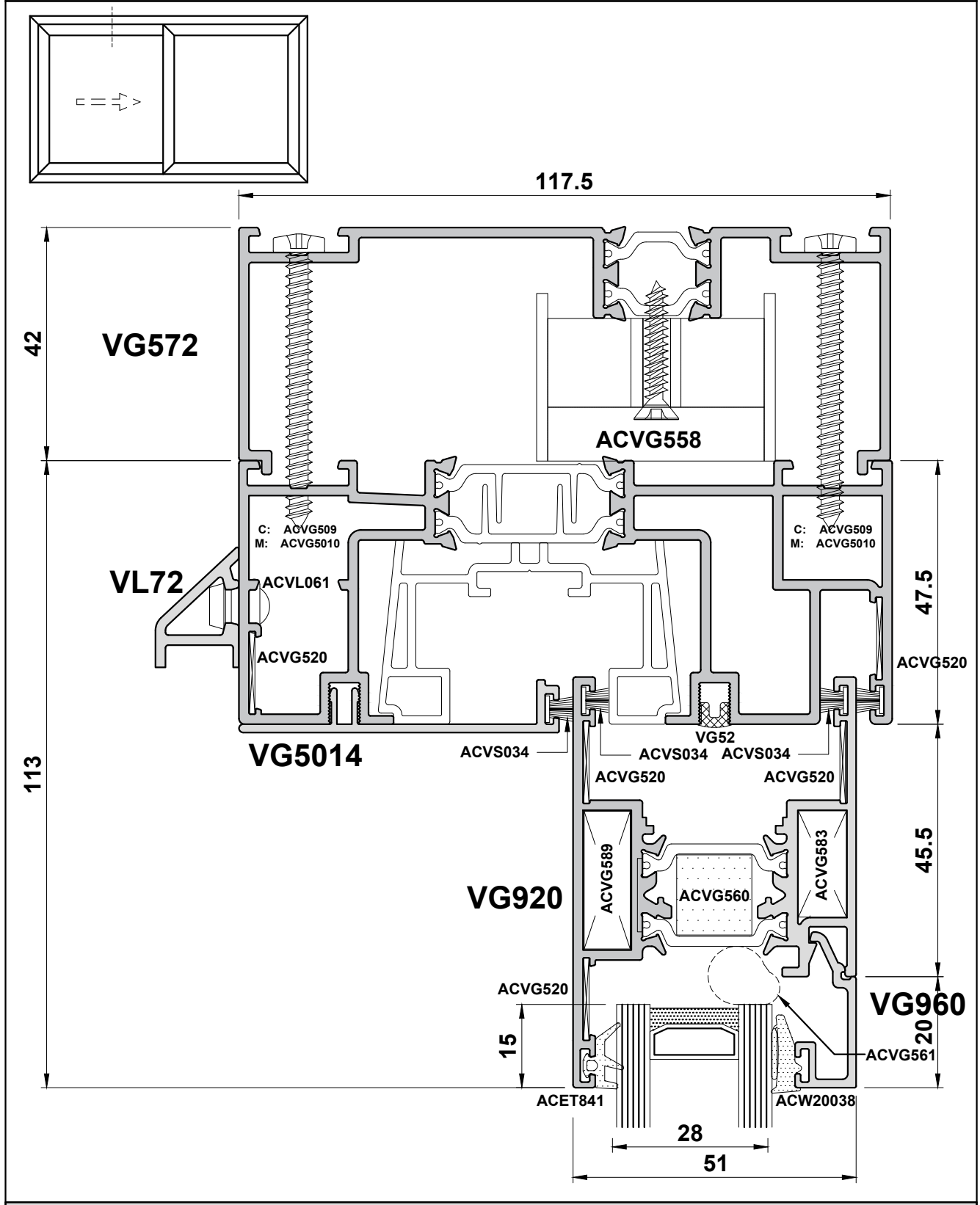
Do Not Scale From This Drawing

Detail 2A



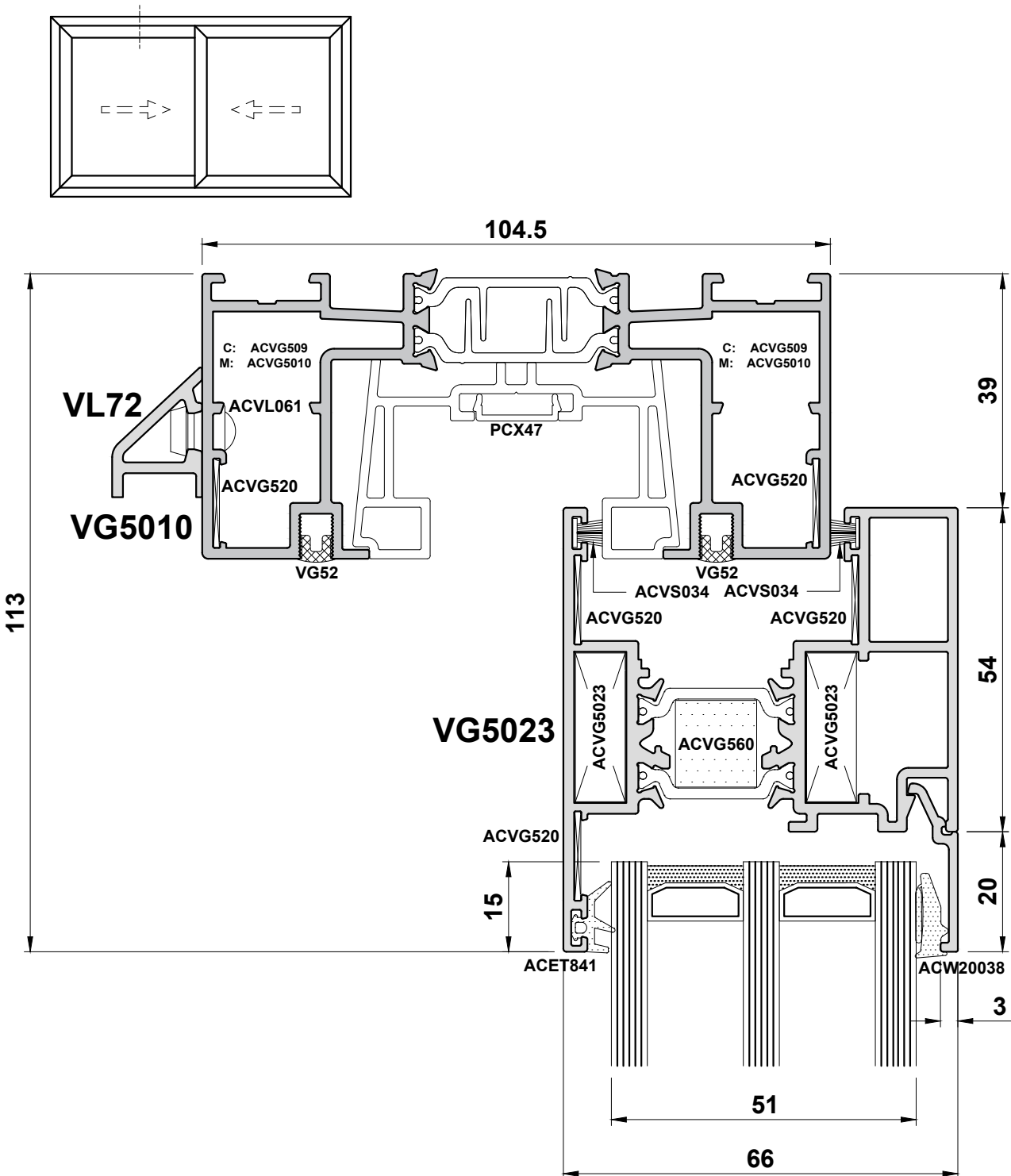
Do Not Scale From This Drawing

Detail 2B



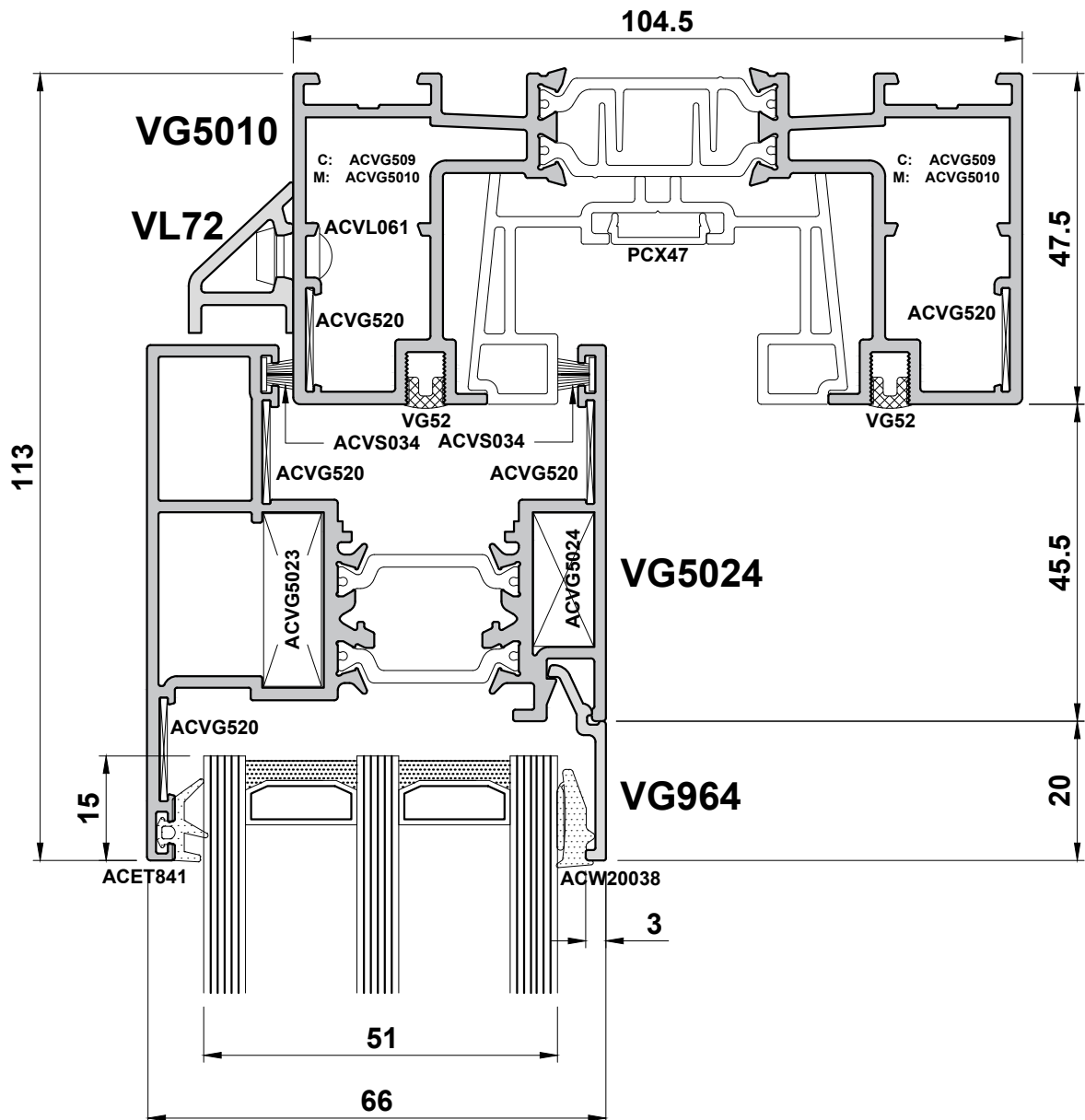
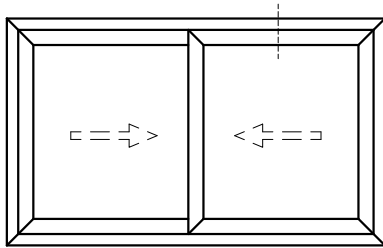
Do Not Scale From This Drawing

Detail 2C



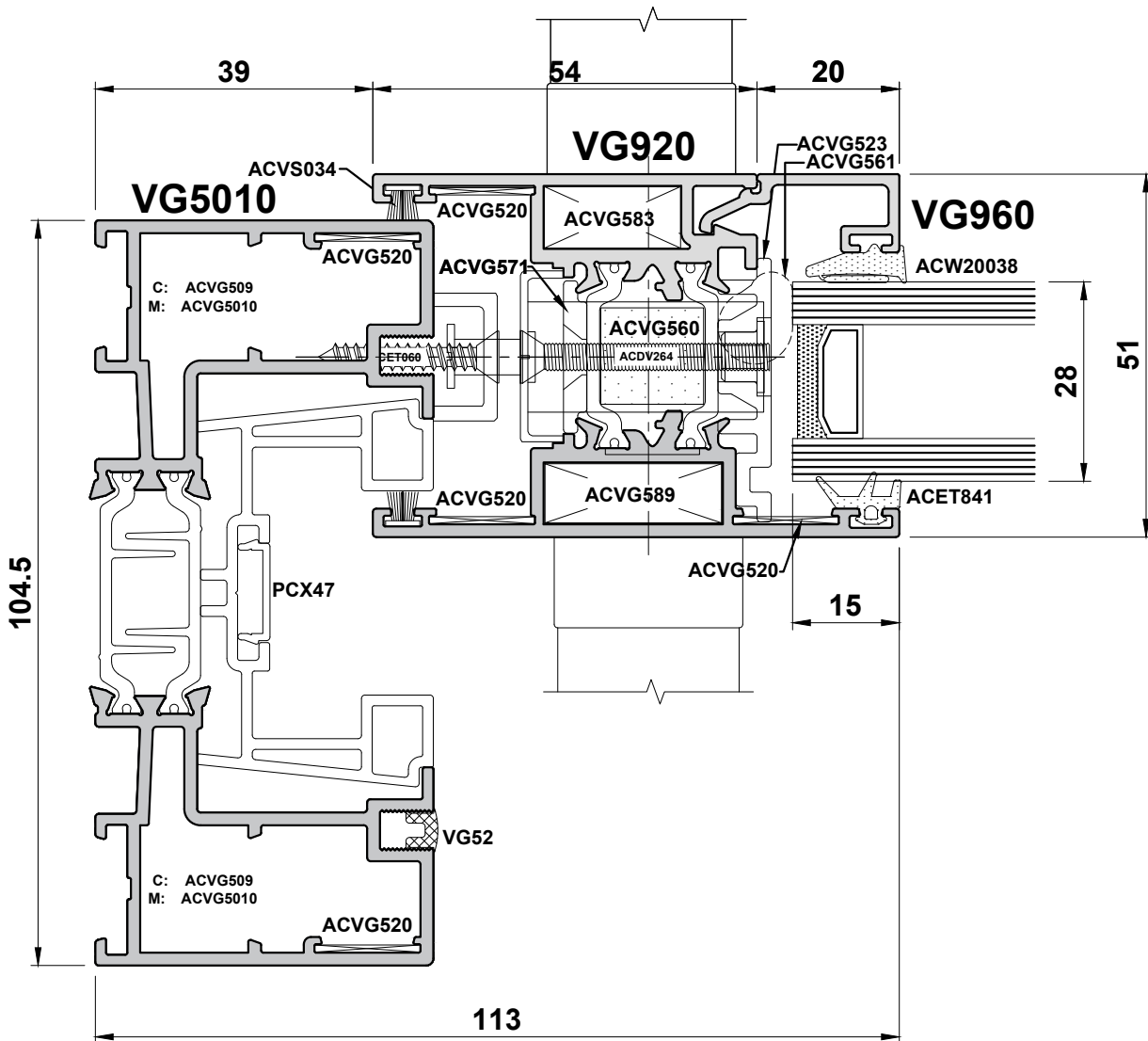
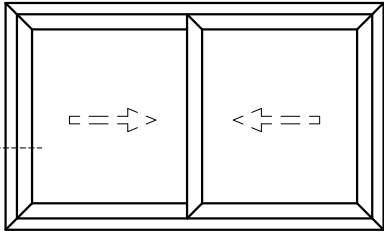
Do Not Scale From This Drawing

Detail 2D



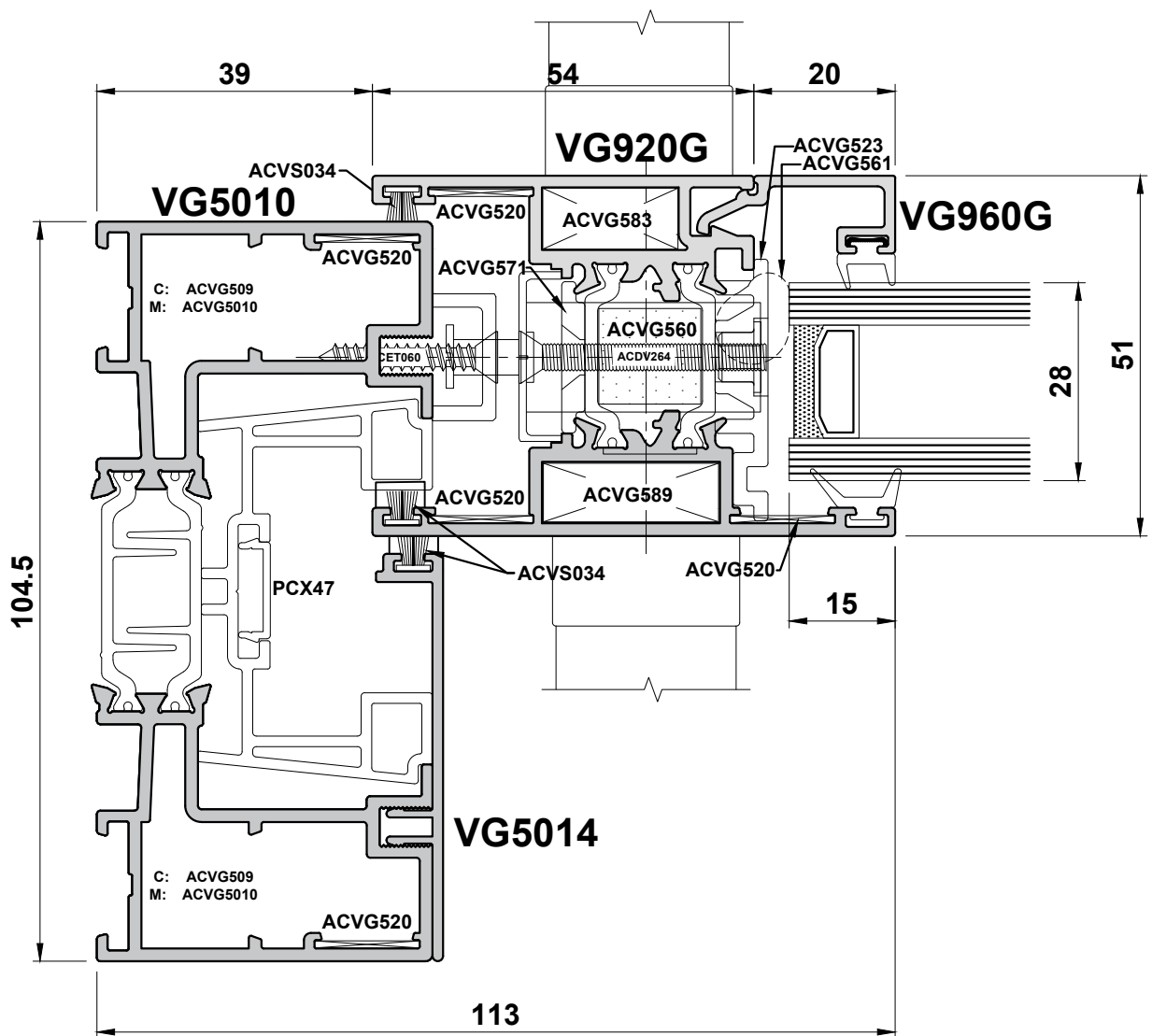
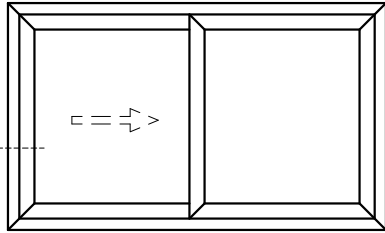
Do Not Scale From This Drawing

Detail 3A



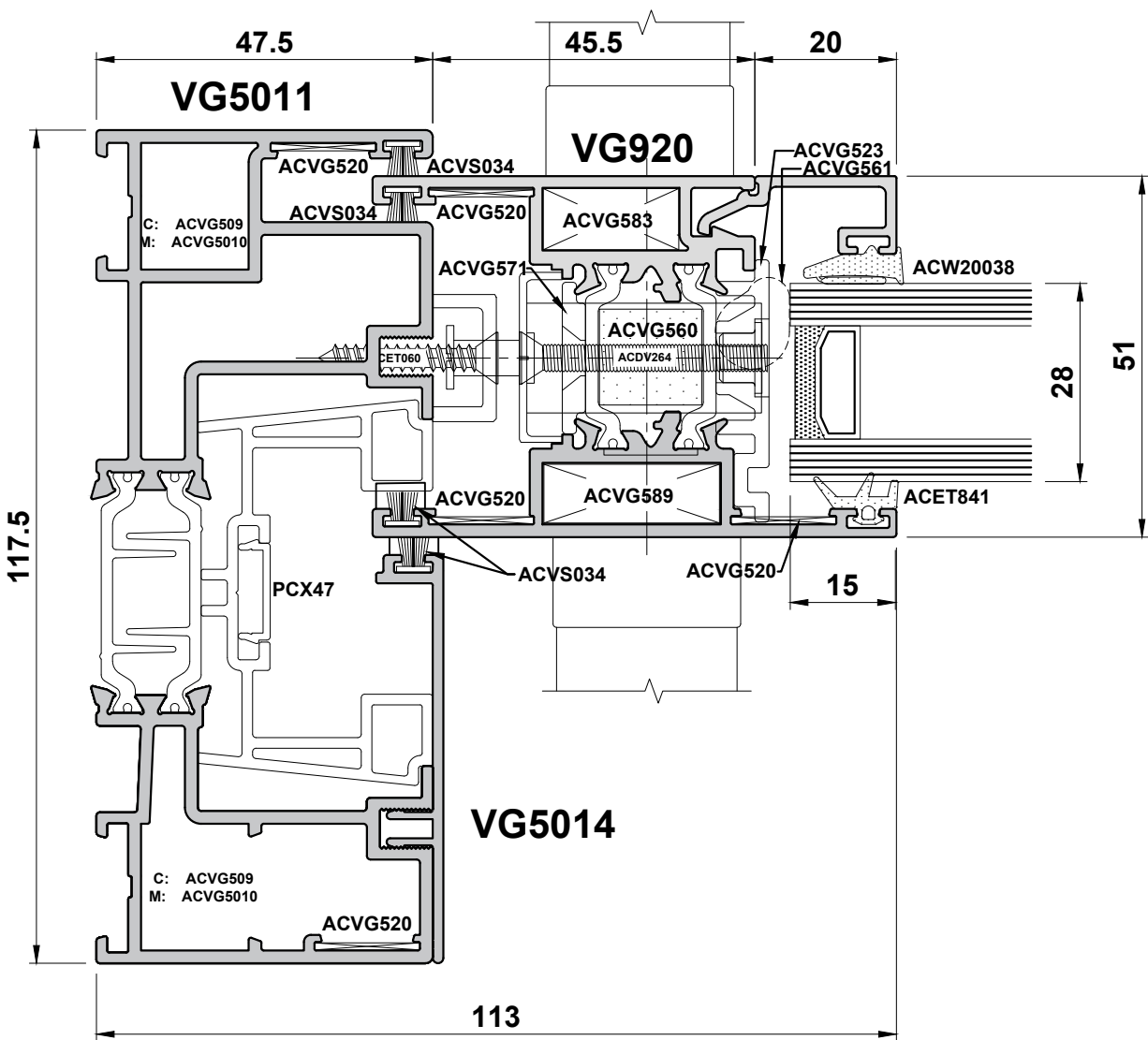
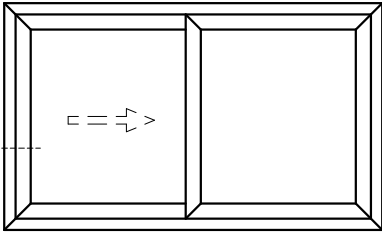
Do Not Scale From This Drawing

Detail 3B



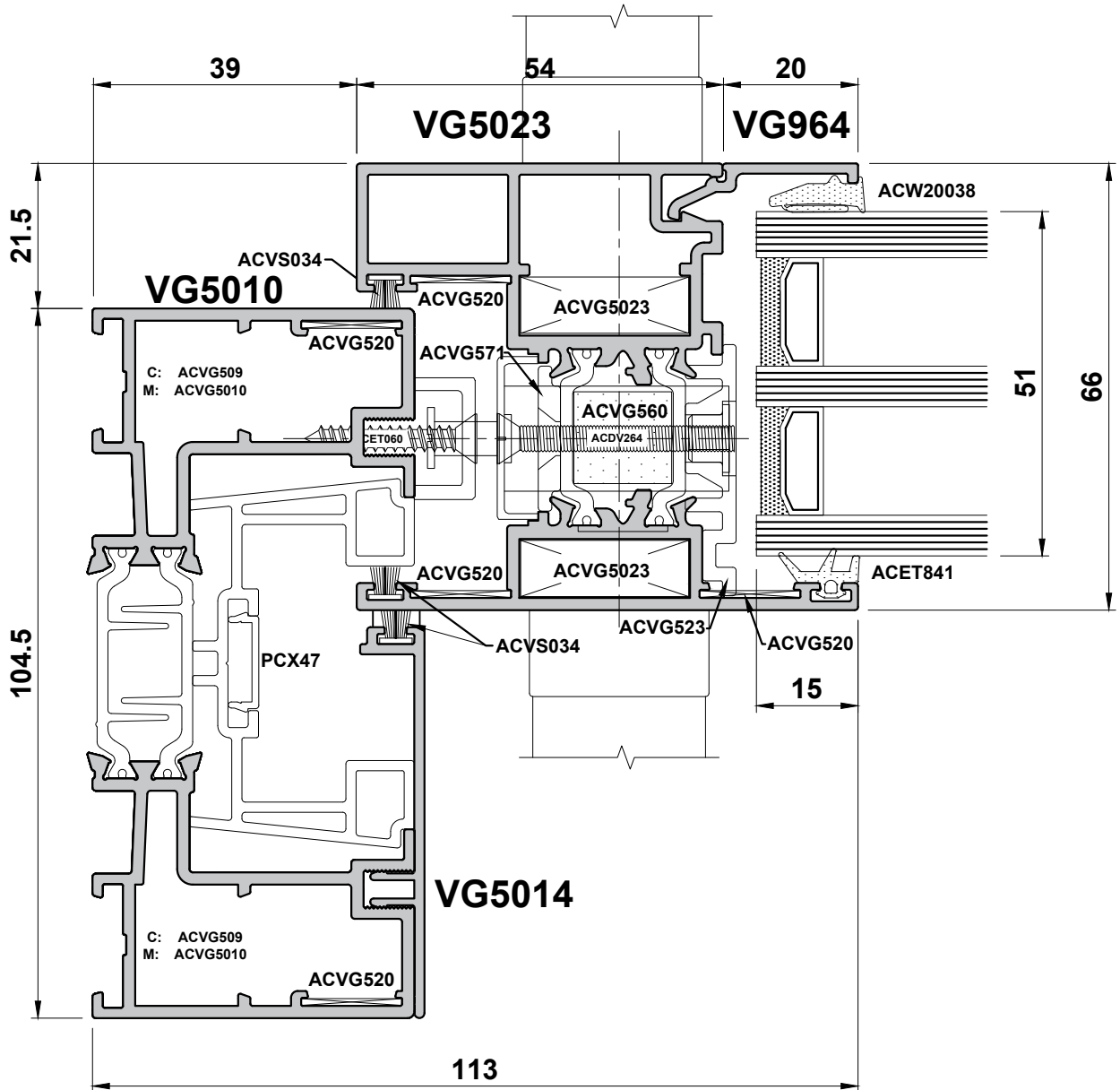
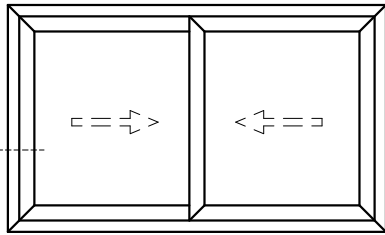
Do Not Scale From This Drawing

Detail 3C



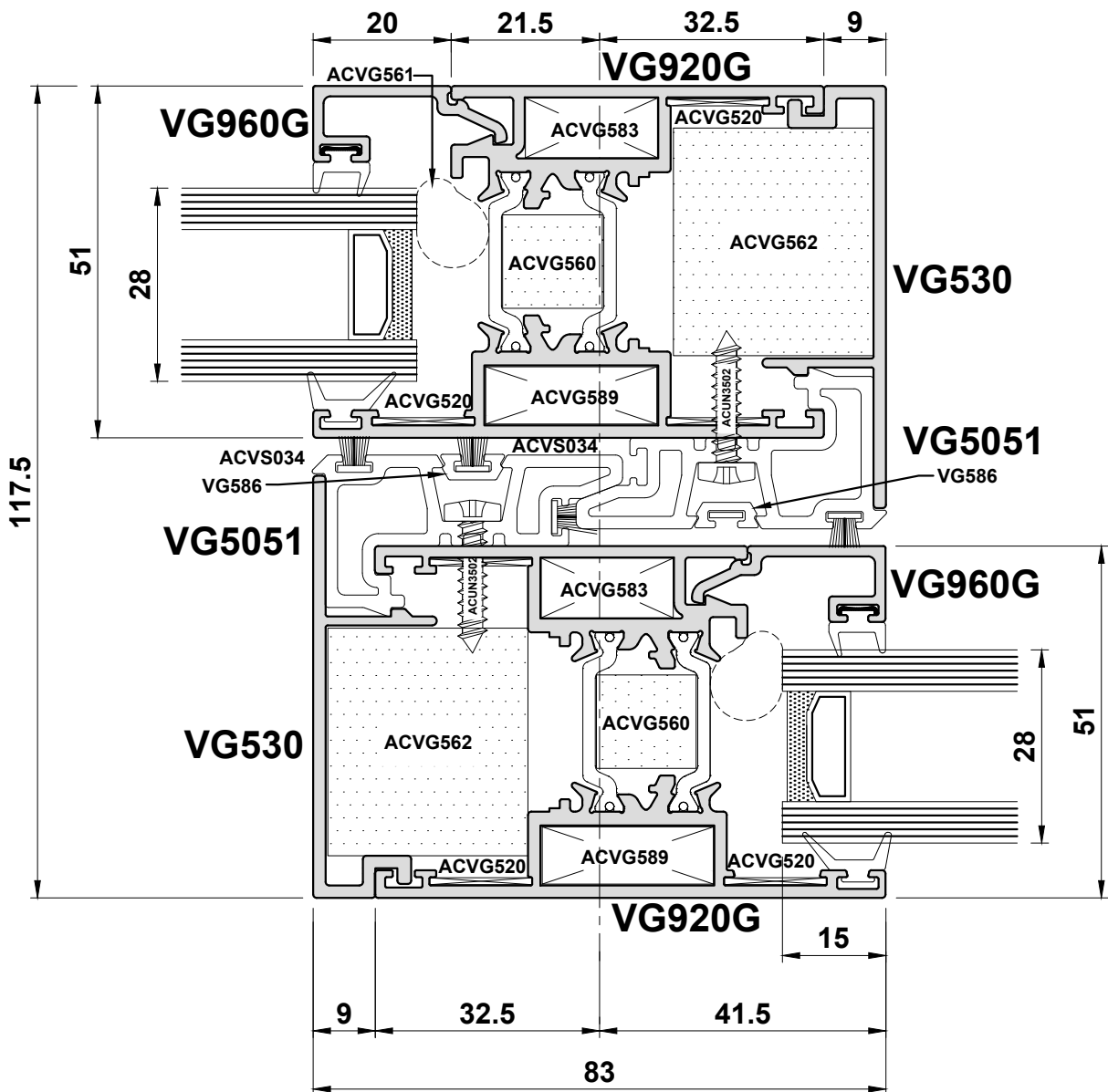
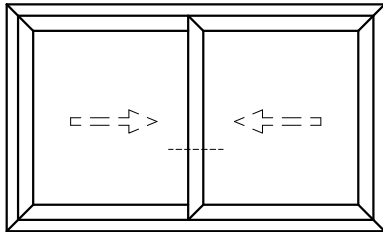
Do Not Scale From This Drawing

Detail 3C



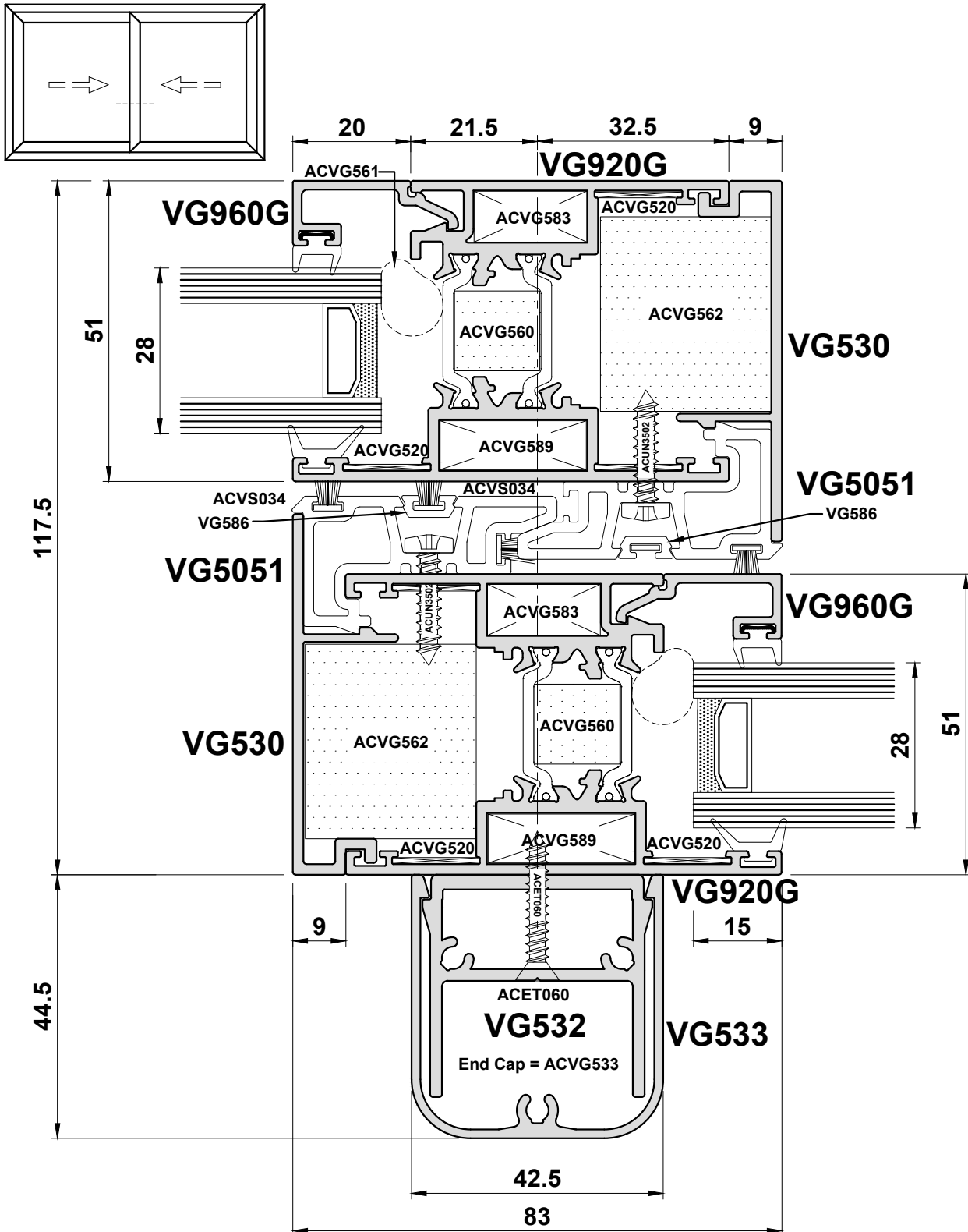
Do Not Scale From This Drawing

Detail 4A



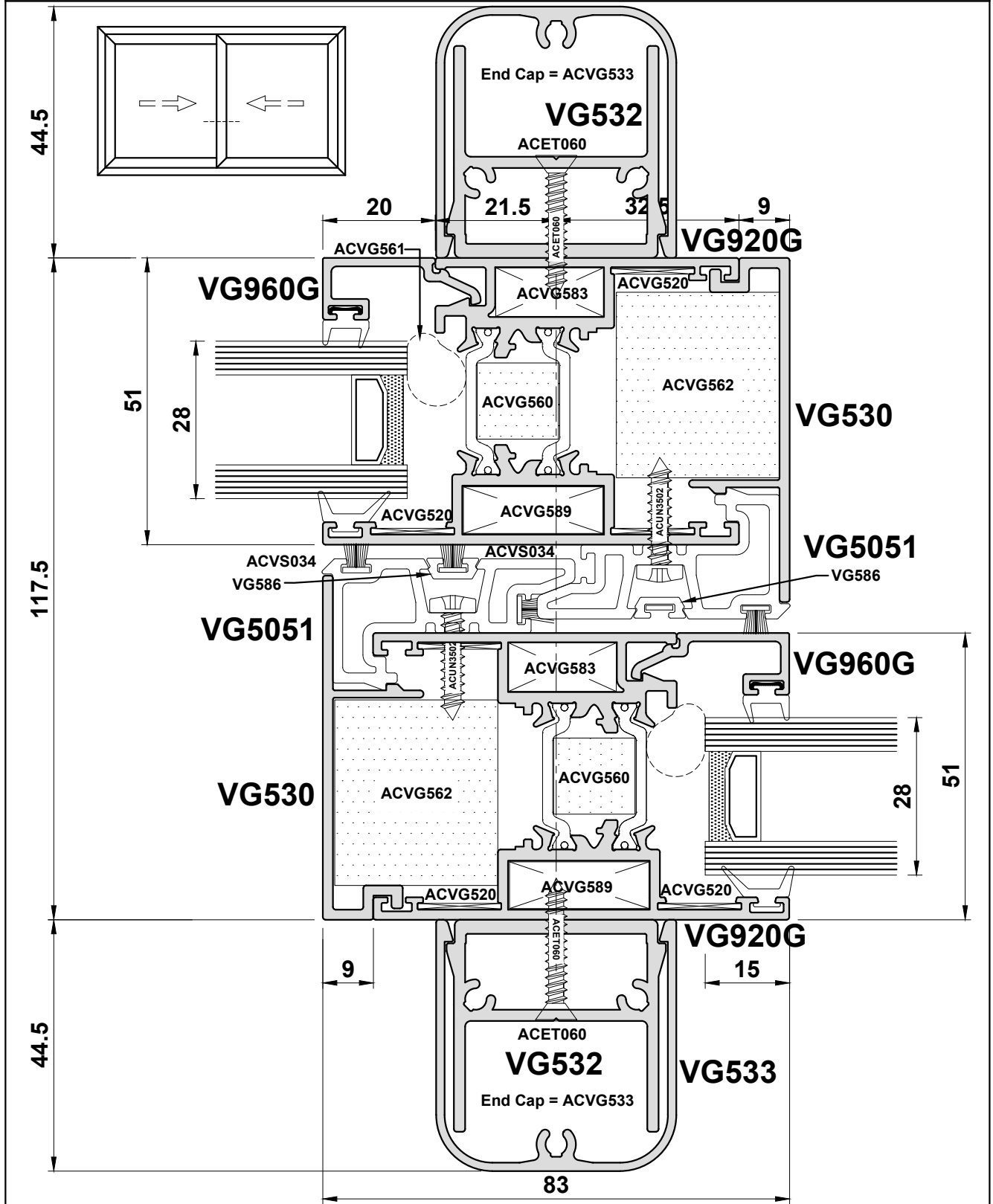
Do Not Scale From This Drawing

Detail 4B



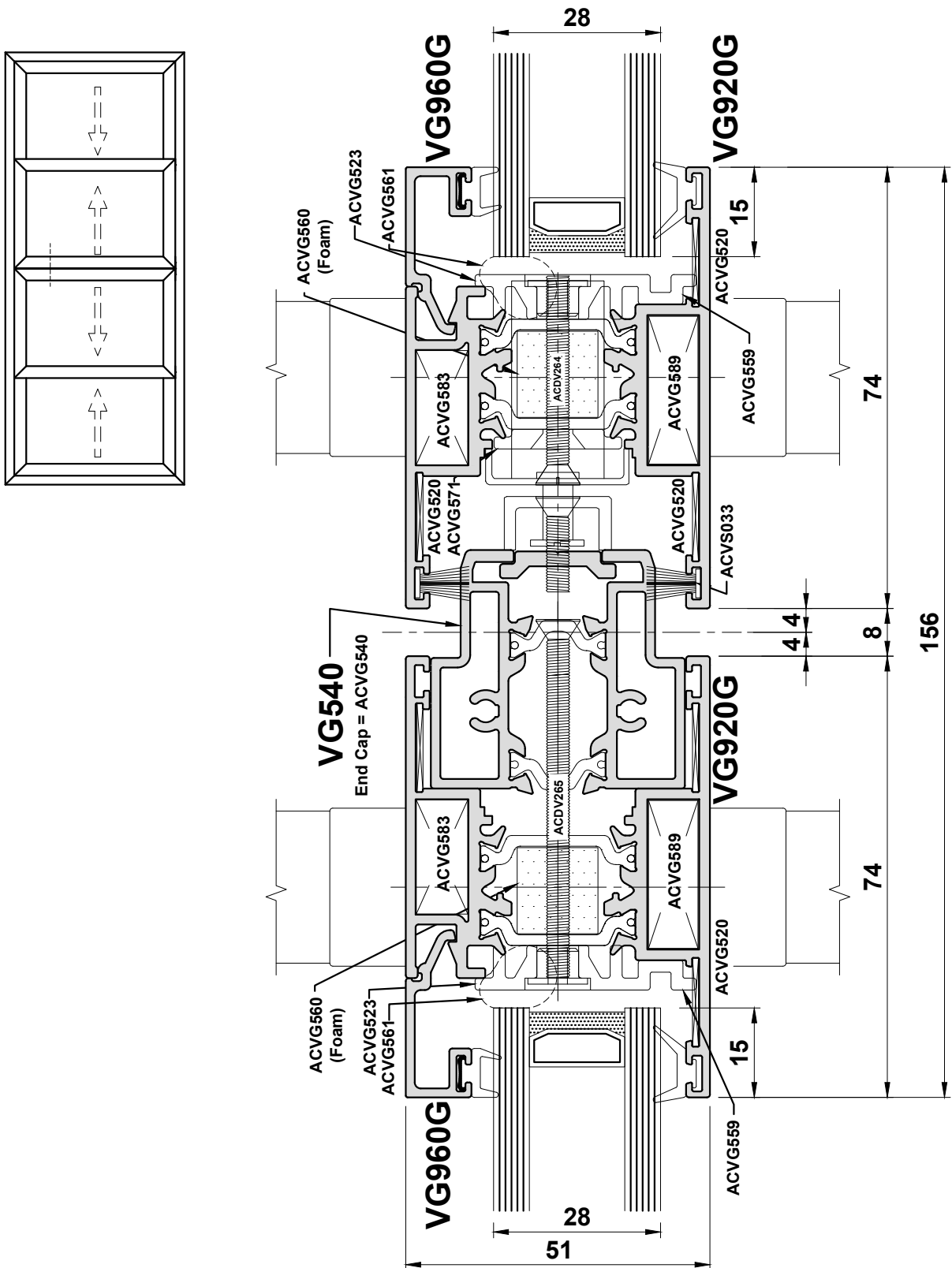
Do Not Scale From This Drawing

Detail 4C



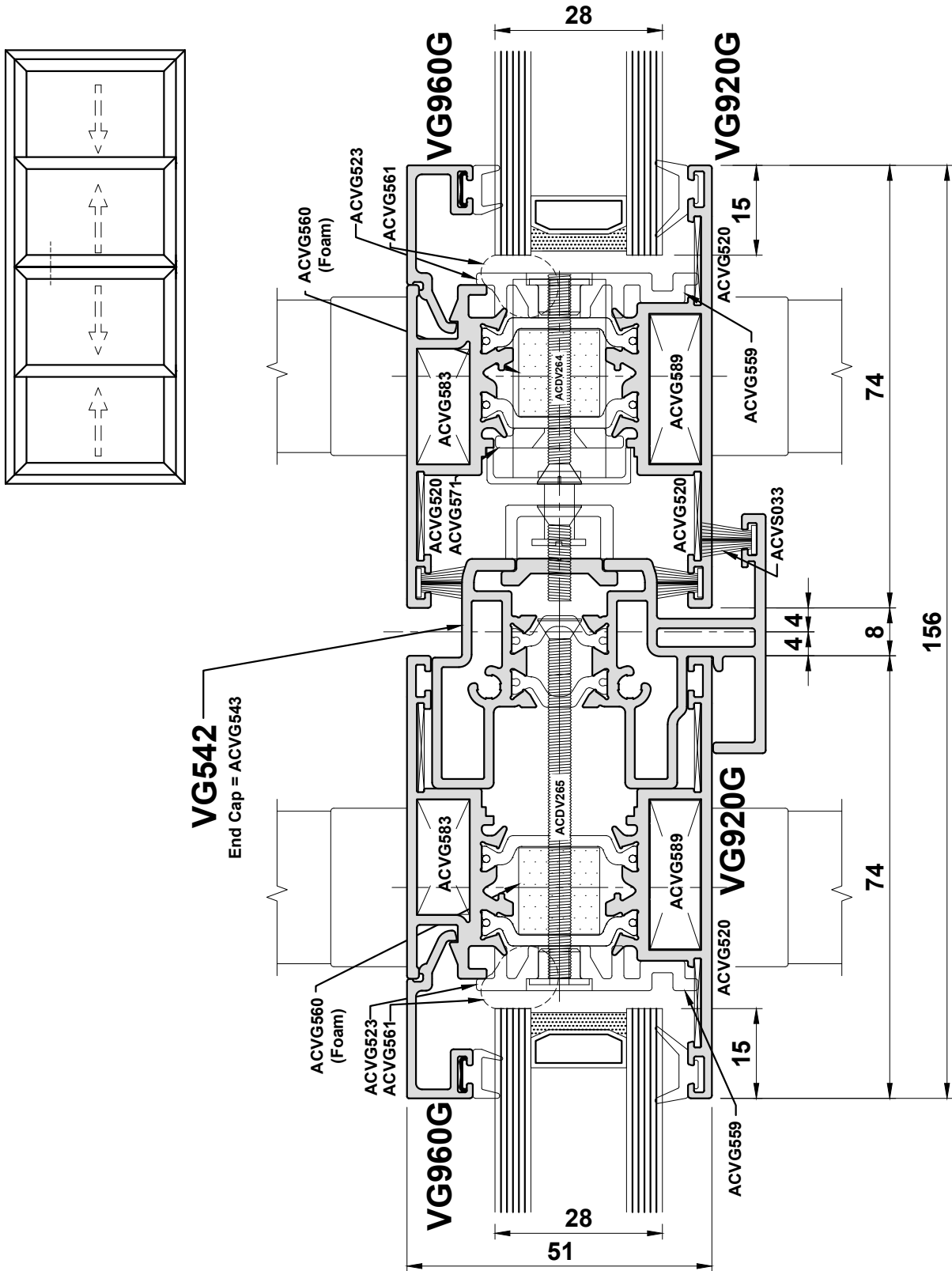
Do Not Scale From This Drawing

Detail 5A



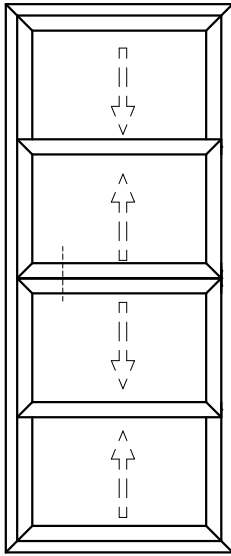
Do Not Scale From This Drawing

Detail 5B



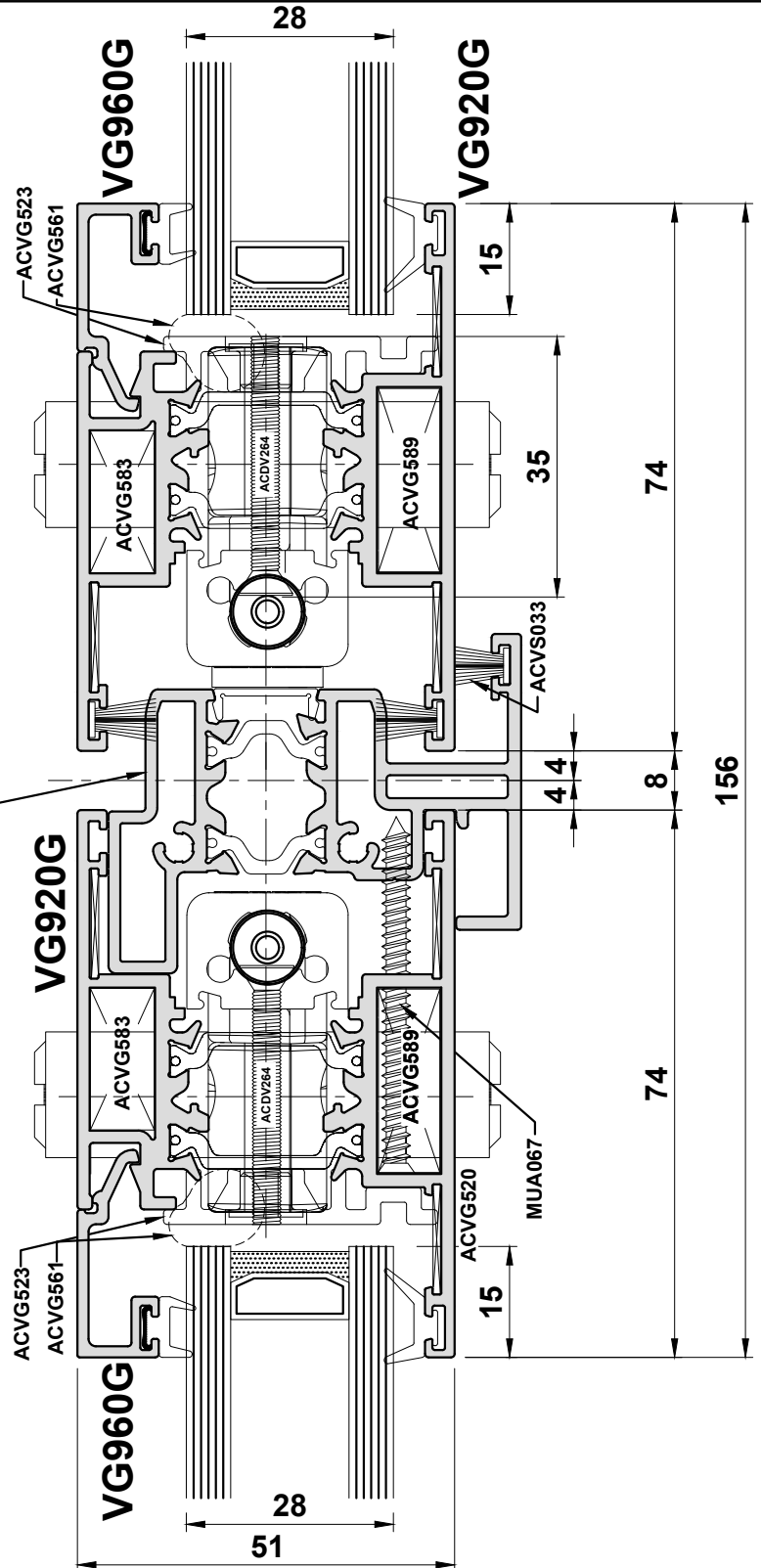
Do Not Scale From This Drawing

Detail 5C



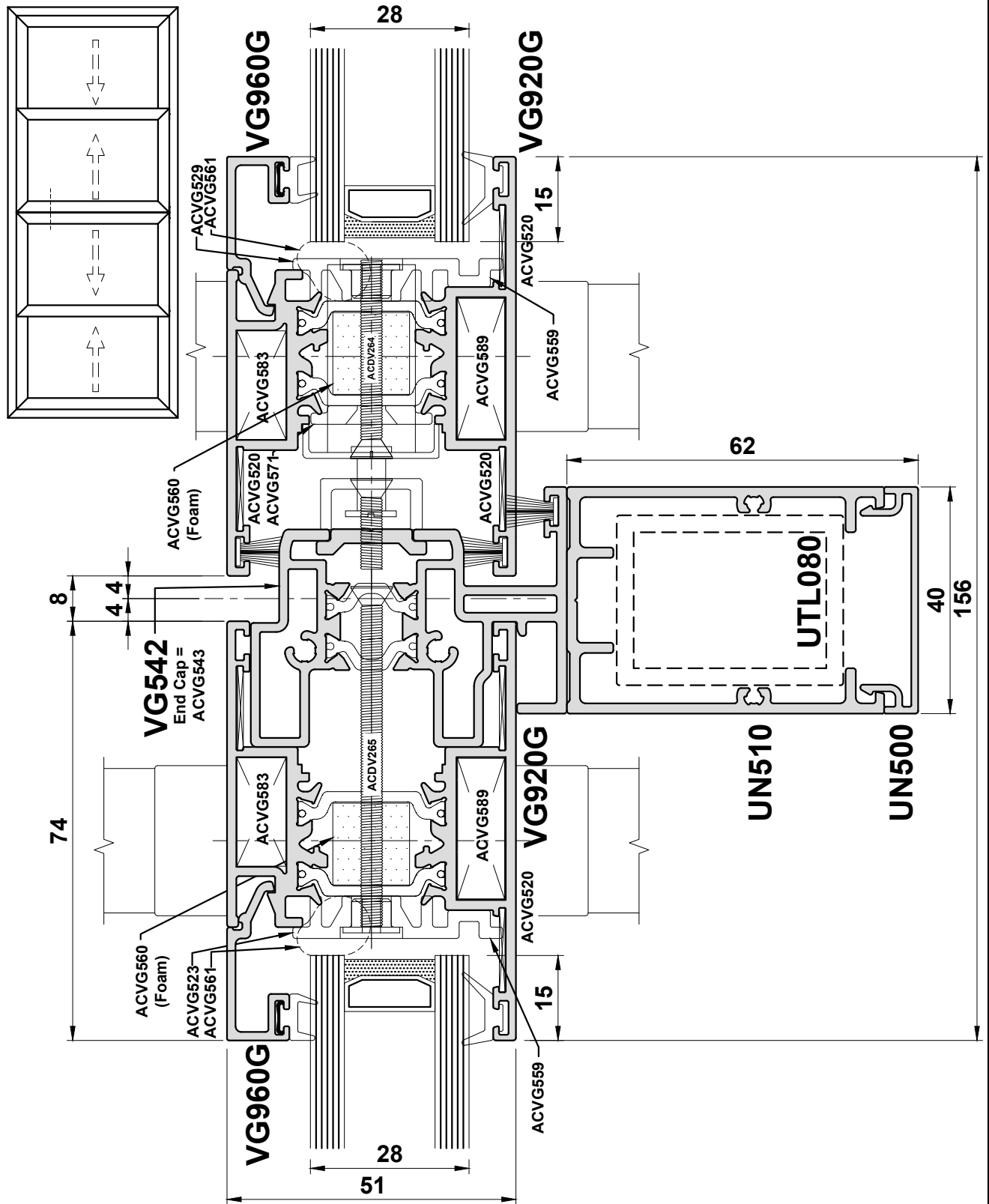
Important Note:
VG549 can only be used with BT Lock

VG549
End Cap = ACVG569



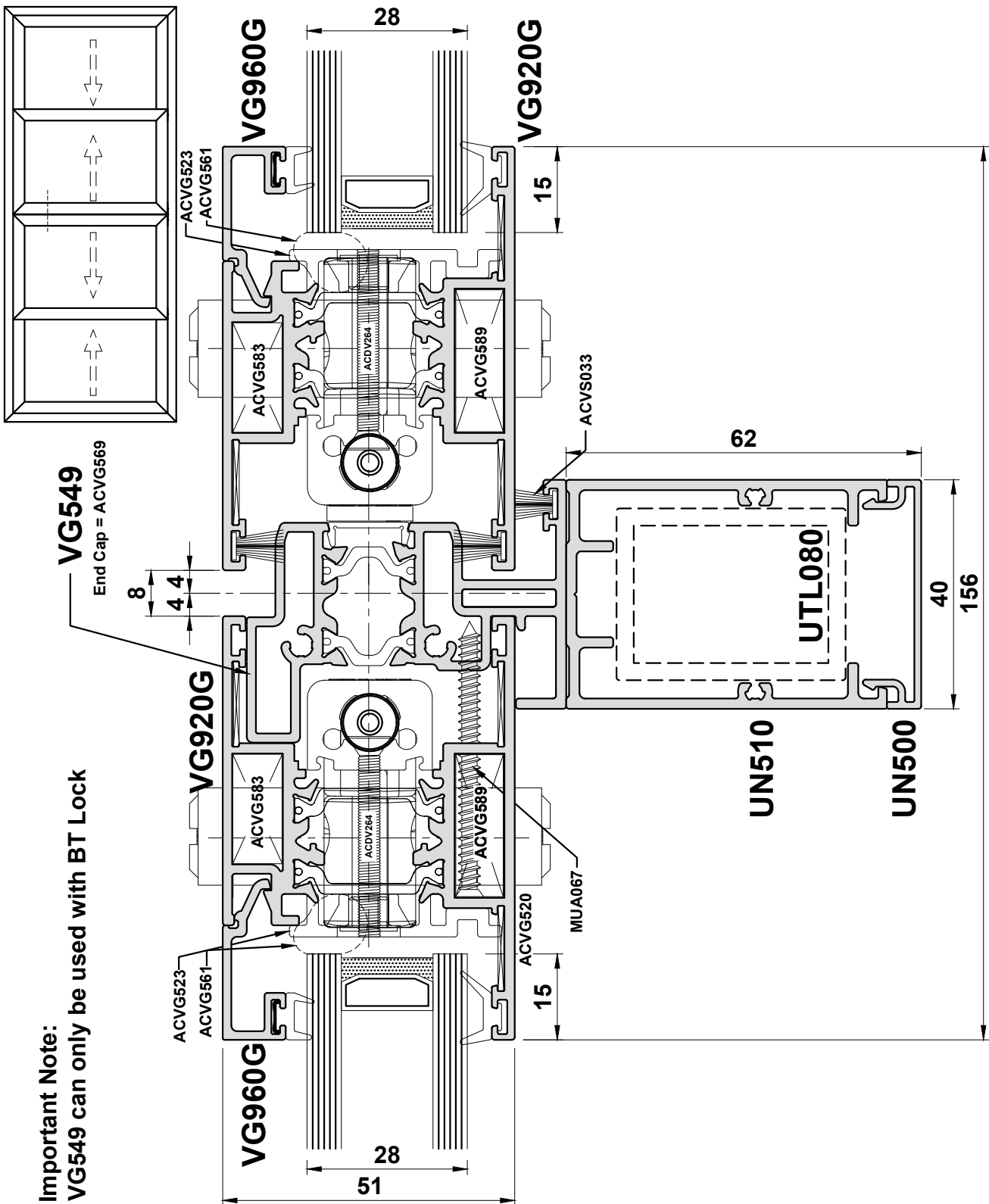
Do Not Scale From This Drawing

Detail 5E



Do Not Scale From This Drawing

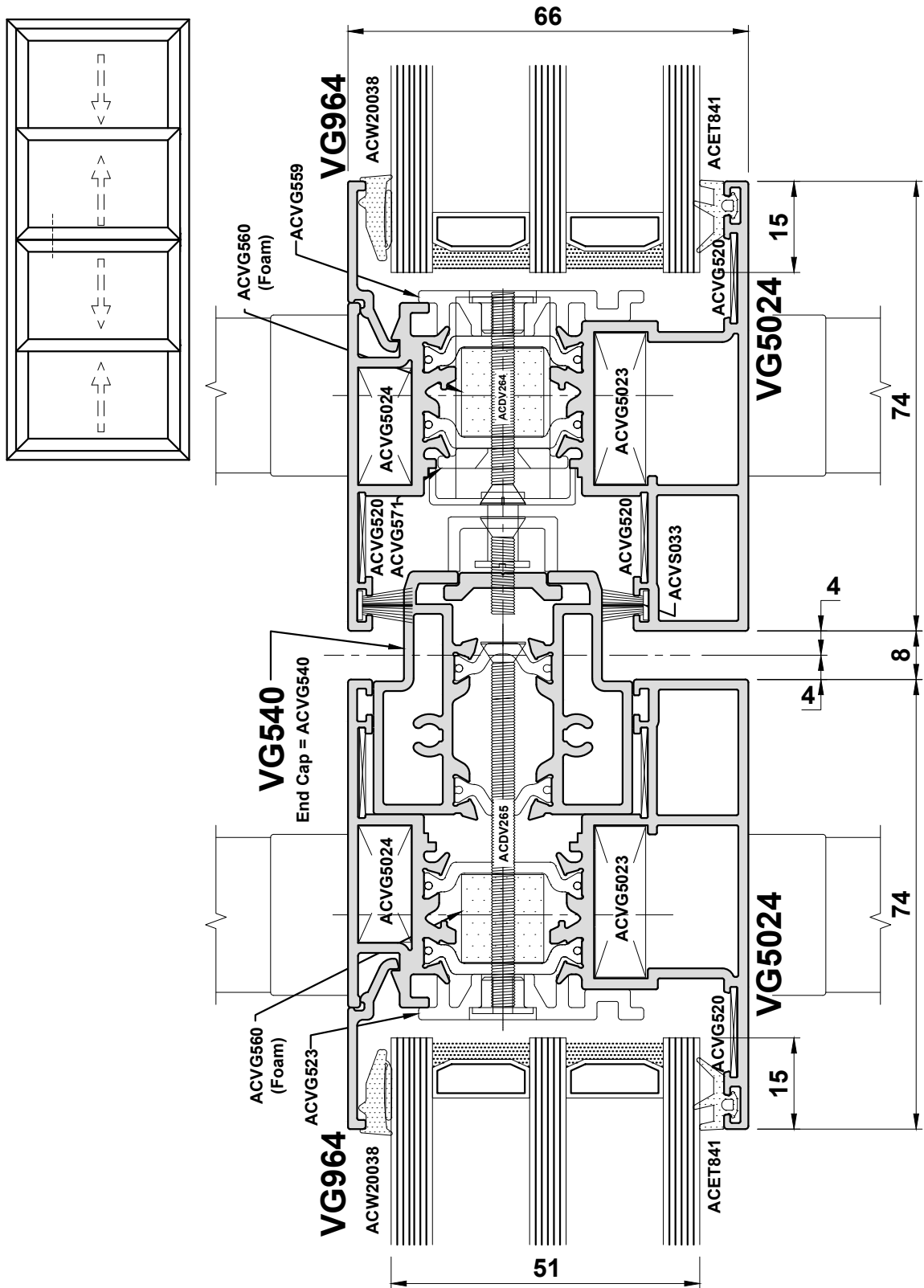
Detail 5F



Important Note:
VG549 can only be used with BT Lock

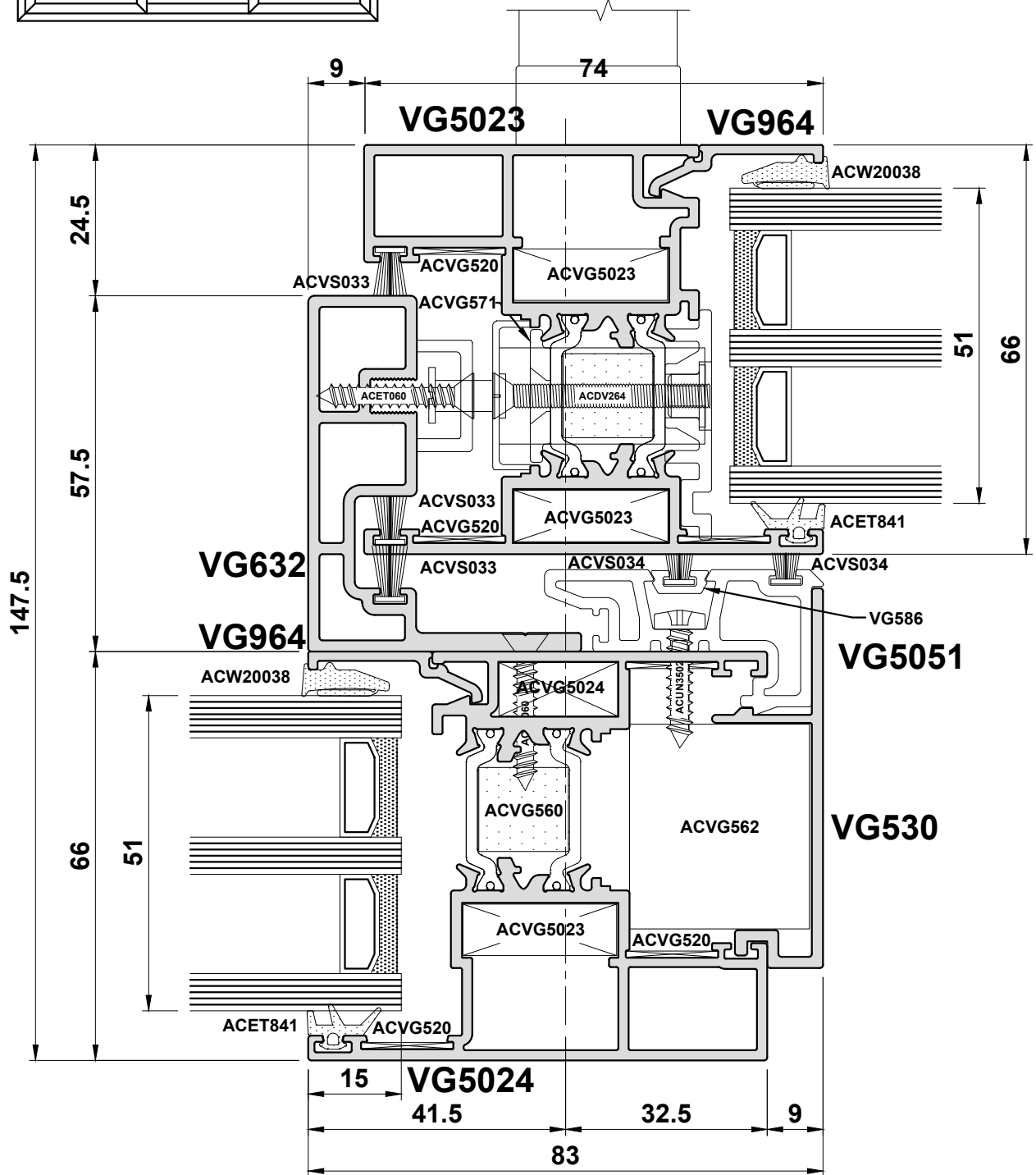
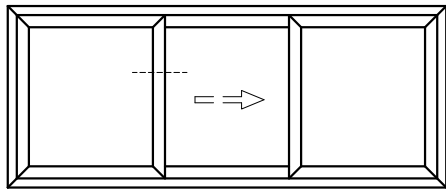
Do Not Scale From This Drawing

Detail 5G

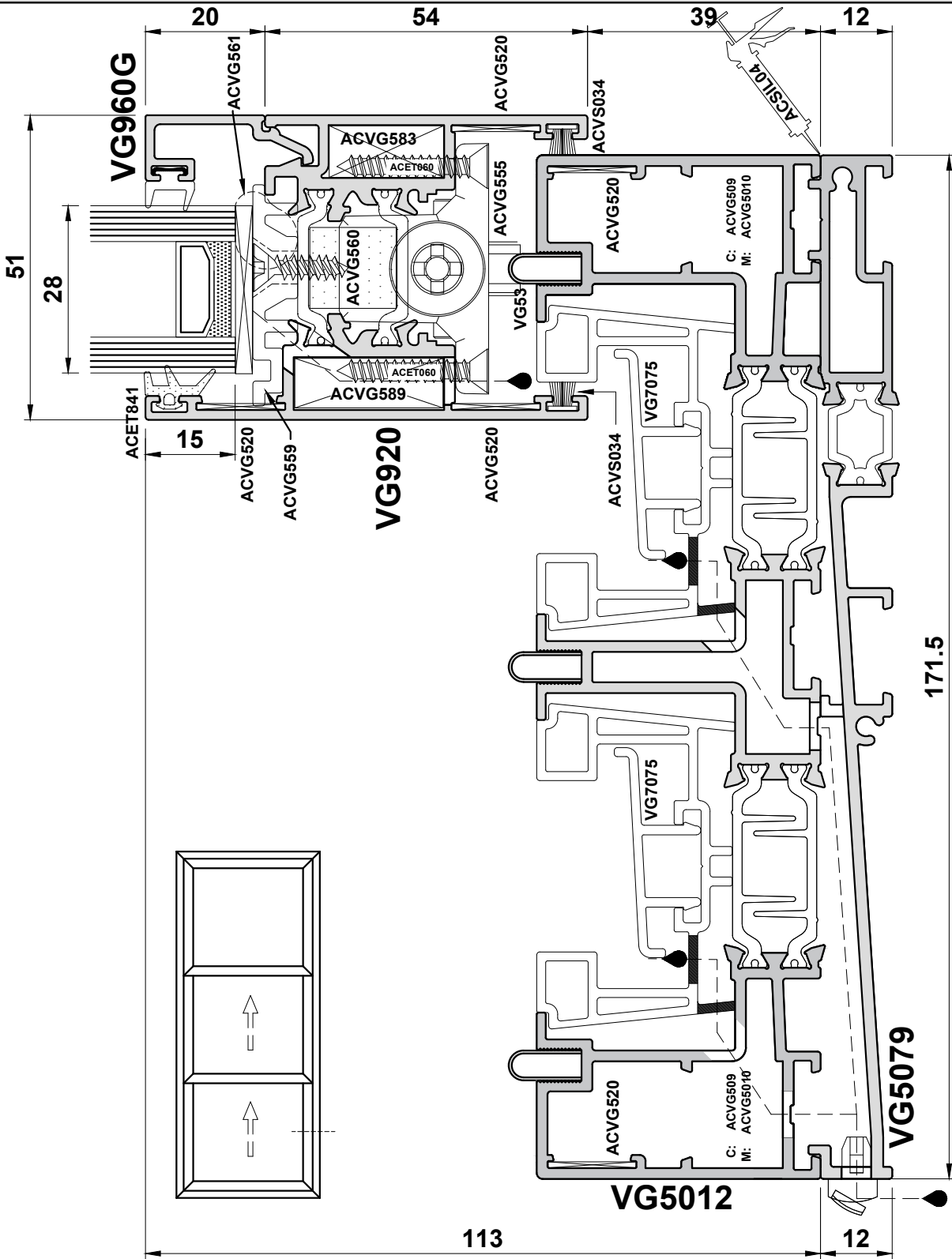


Do Not Scale From This Drawing

Detail 6B

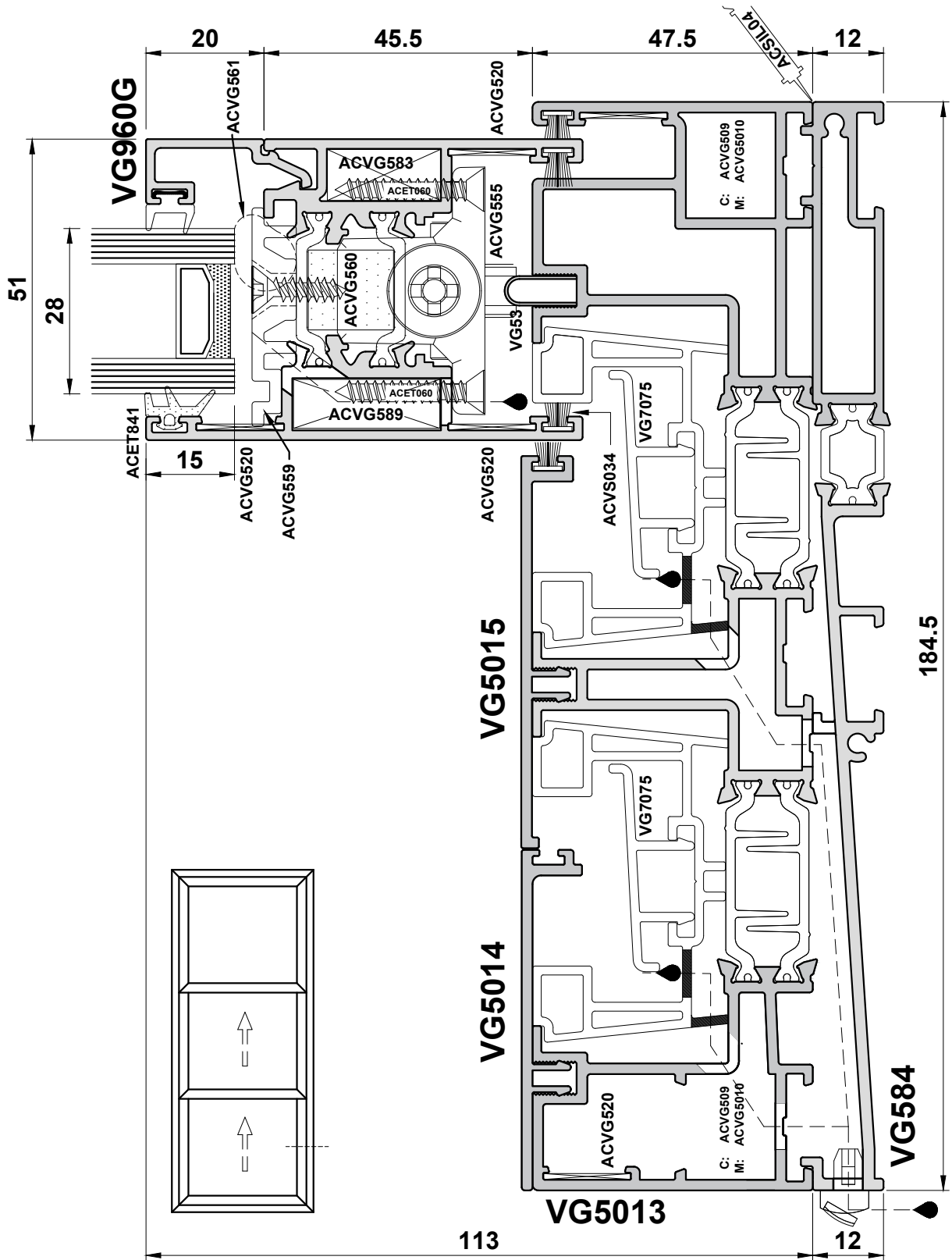


Detail 7A



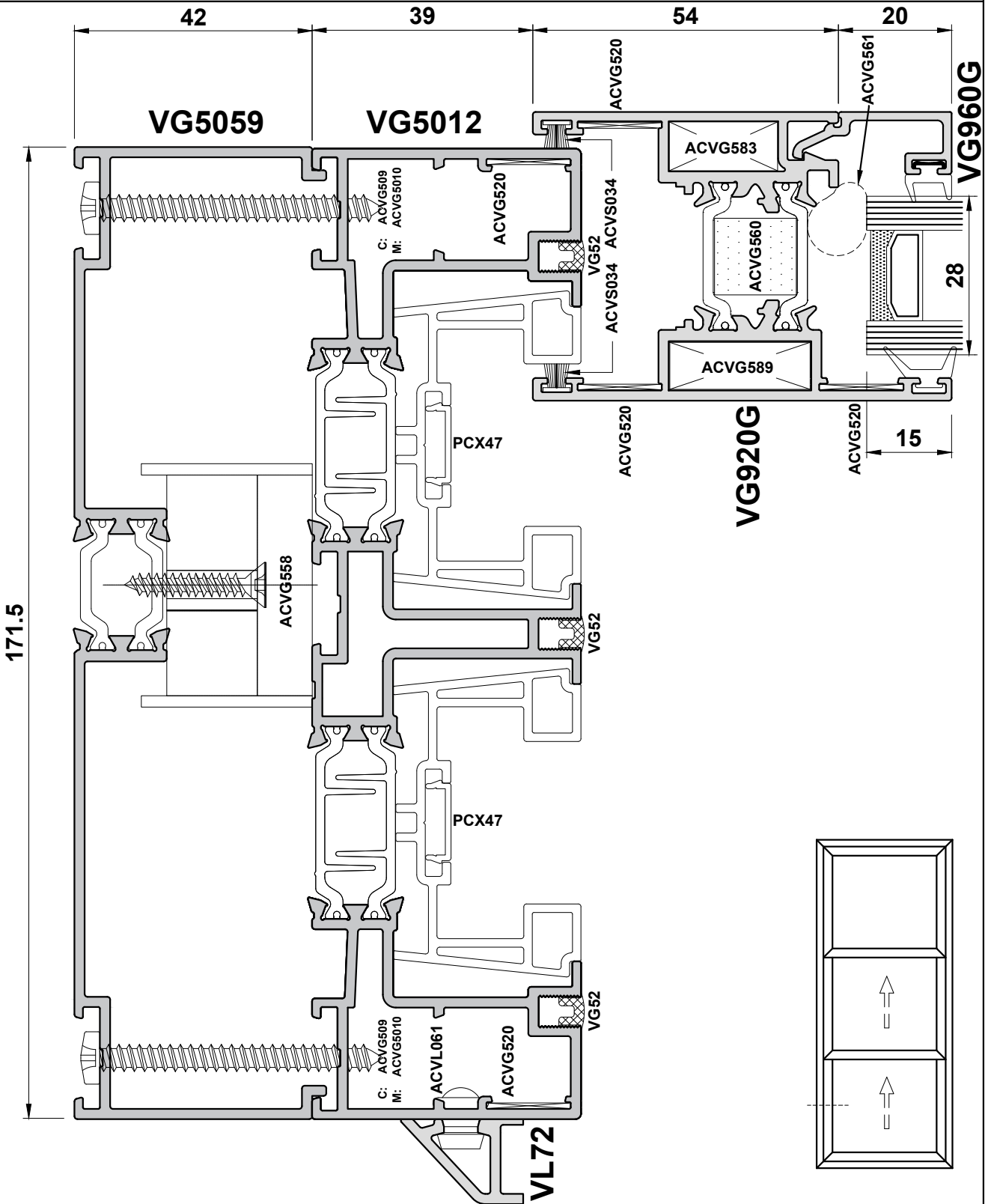
Do Not Scale From This Drawing

Detail 7B



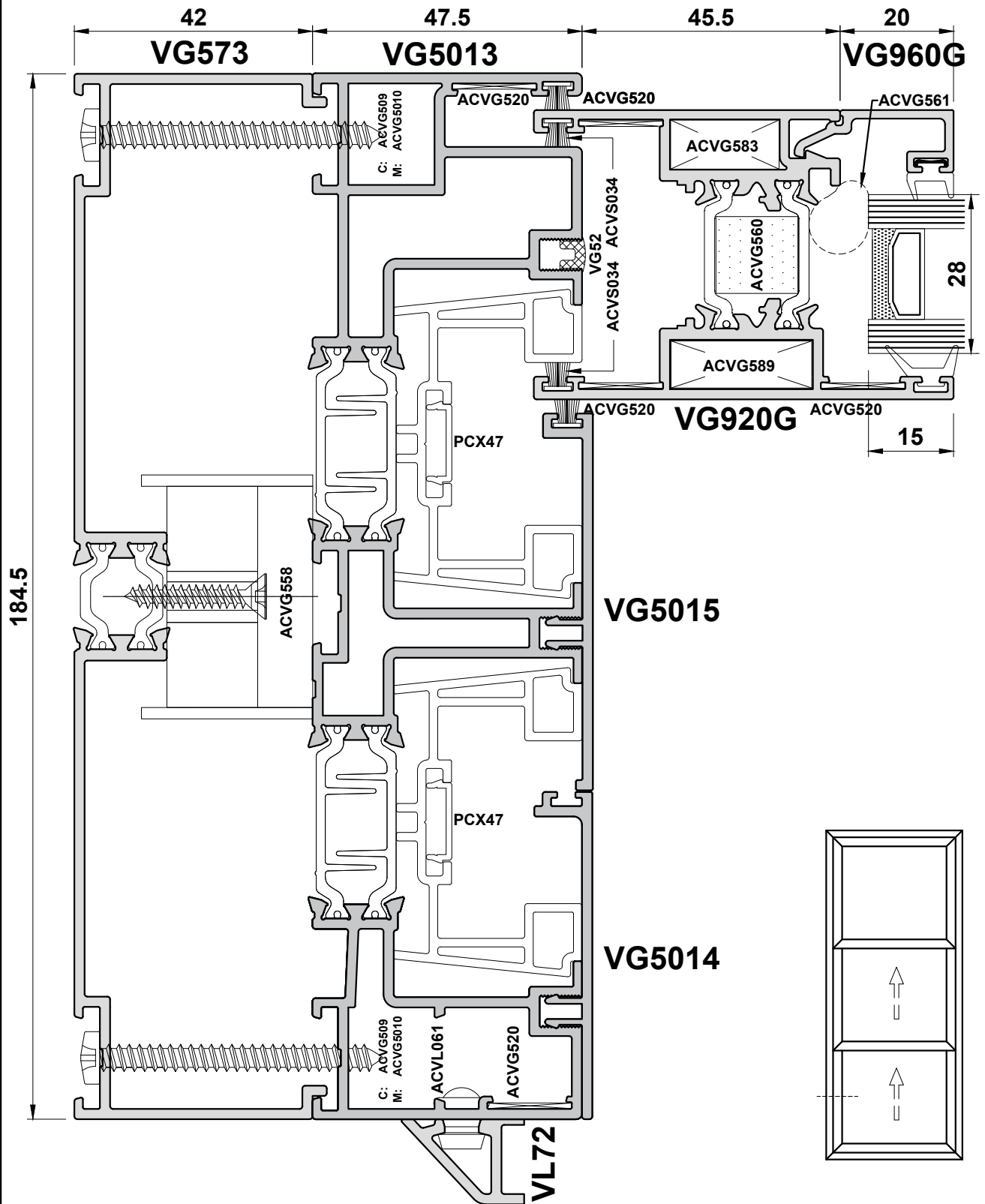
Do Not Scale From This Drawing

Detail 8A



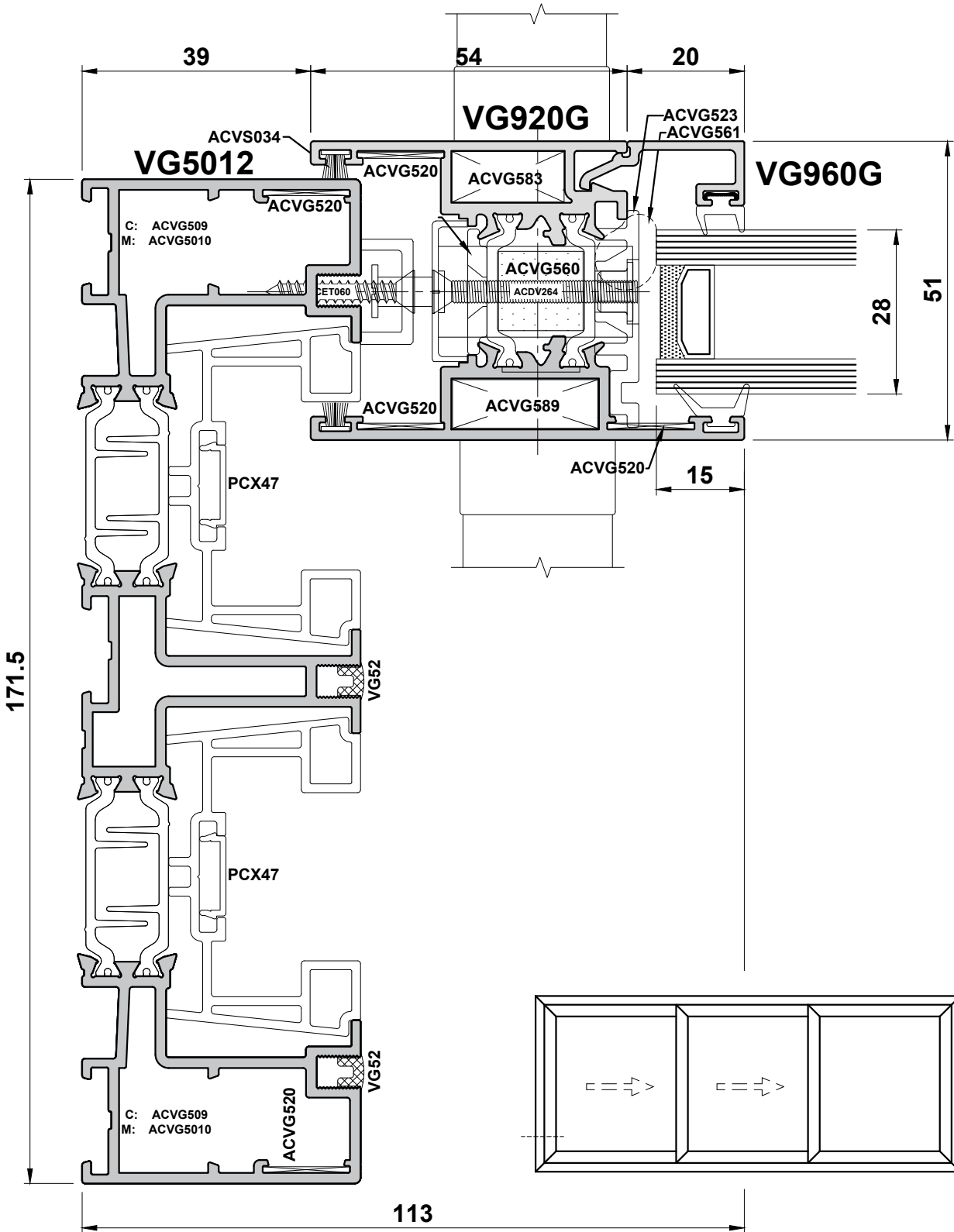
Do Not Scale From This Drawing

Detail 8B

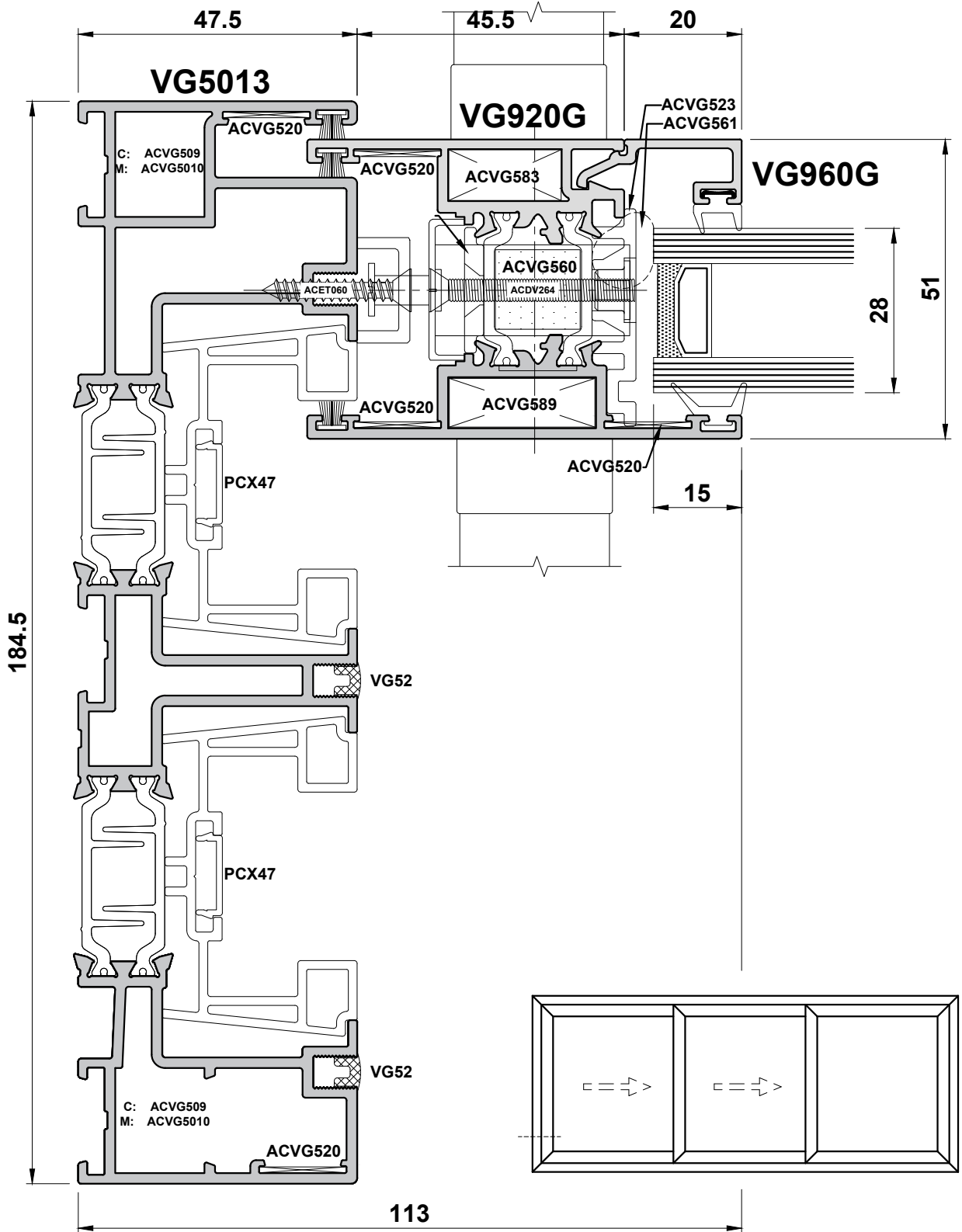


Do Not Scale From This Drawing

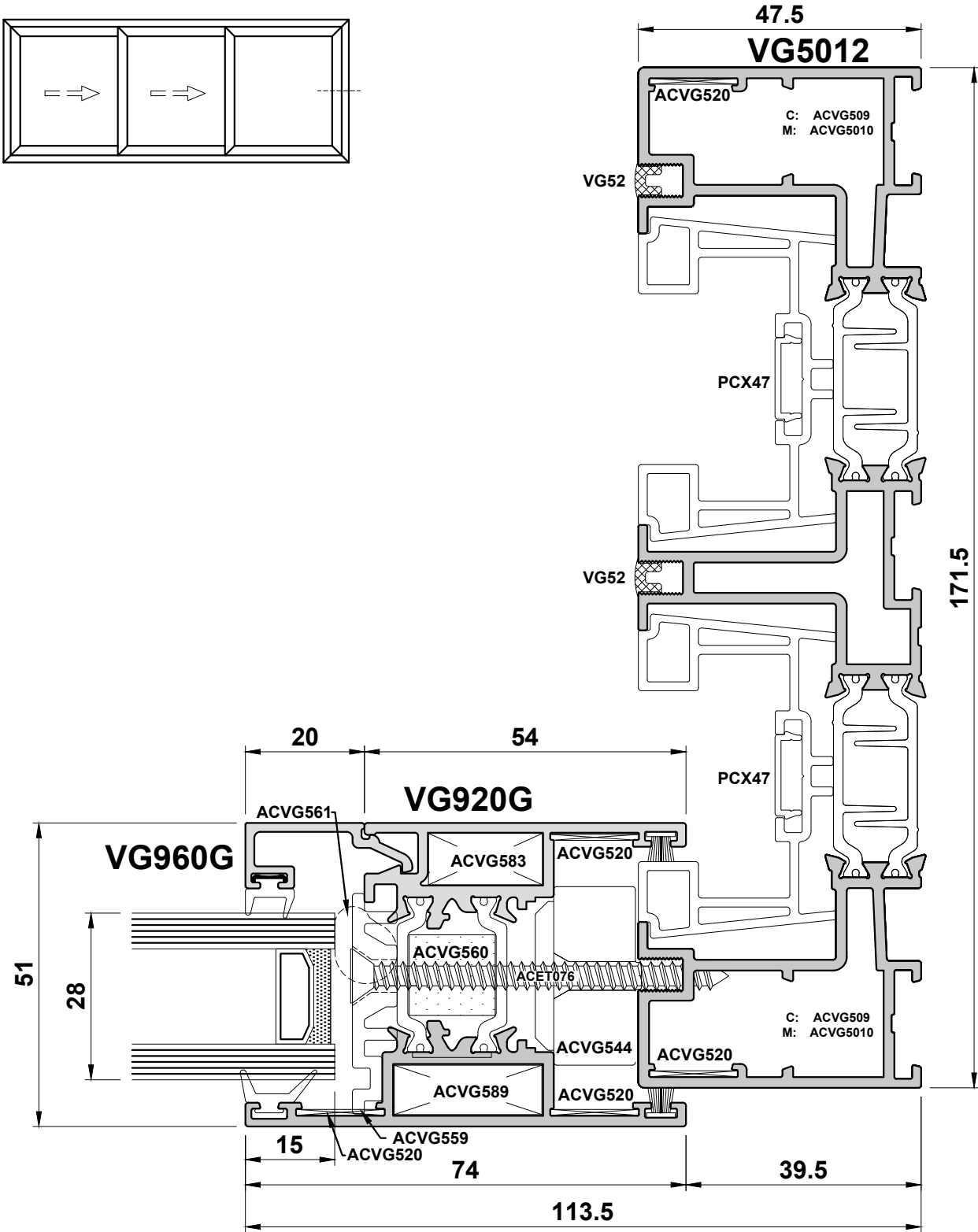
Detail 9A



Detail 9B



Detail 10



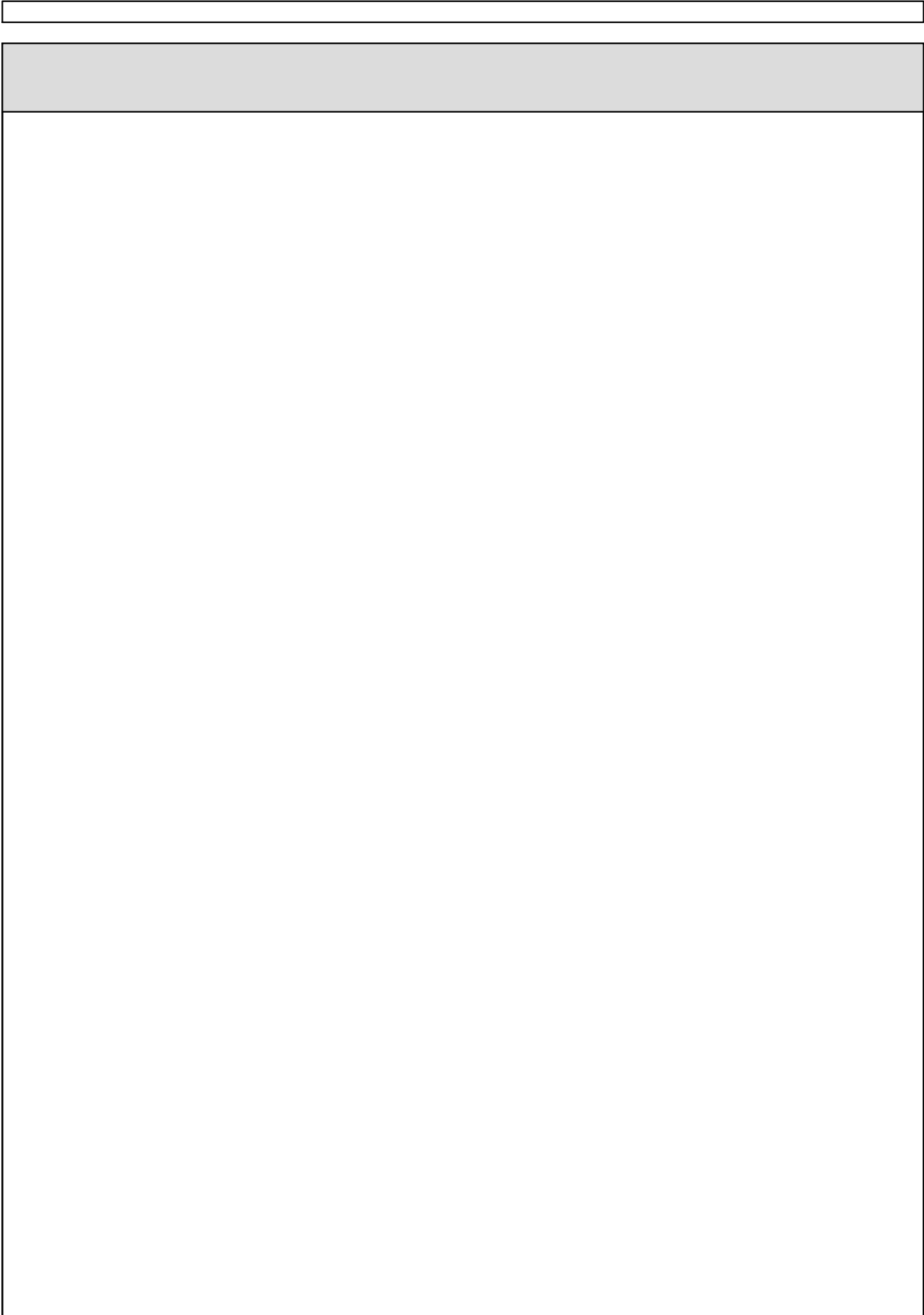
Do Not Scale From This Drawing

Section D

Statics

**General Size Limitations are shown on Page A07 of the
Visoglide Plus manual.**

**If in doubt, please contact
the technical department - T: 01934 876100
E: technicalgroup@smartsystems.co.uk**



Section E

Construction Drawings



Punch Tool Details.....	E03 - E04
Drainage Details.....	E05 - E08
Head Extension Fitting Details.....	E09
Interlock Plug Details.....	E10
Slim Interlock Preparation.....	E11 - E12
Glazing Options.....	E13 - E14

IMPORTANT NOTE:

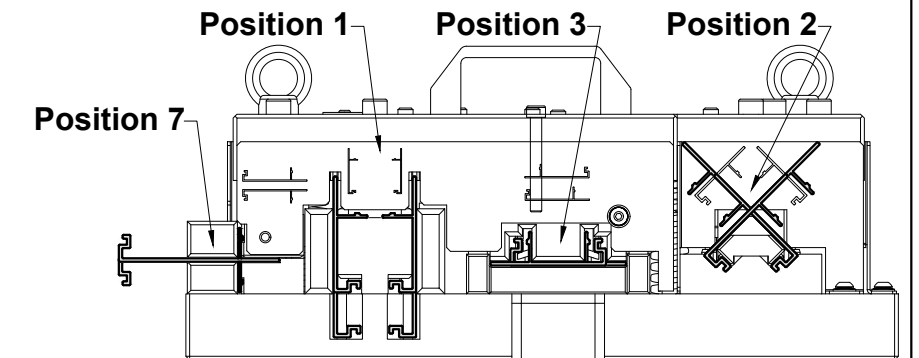
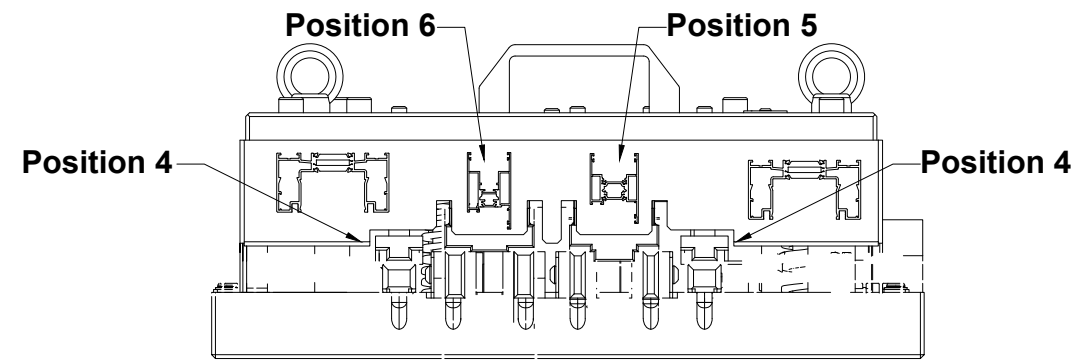
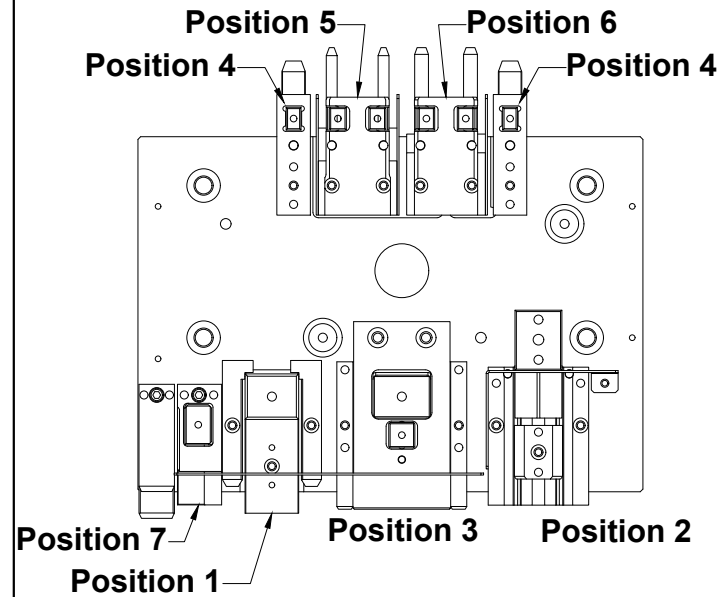
The Visoglide Plus Upgraded sections and accessories shown in this manual share details with the existing Visoglide Plus manual.

Any specific fabrication details are highlighted in this manual.

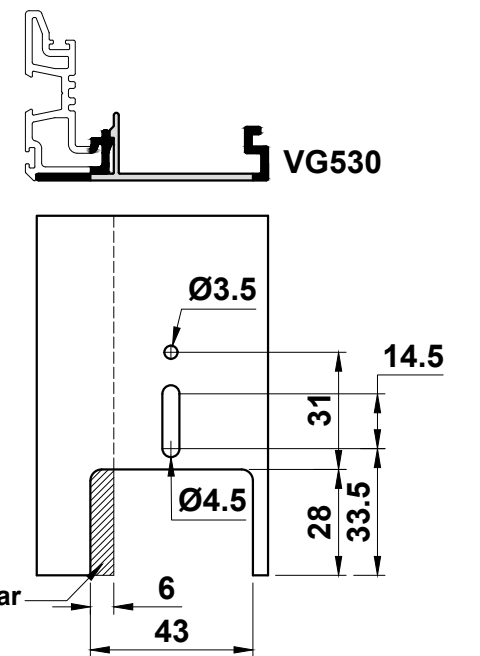
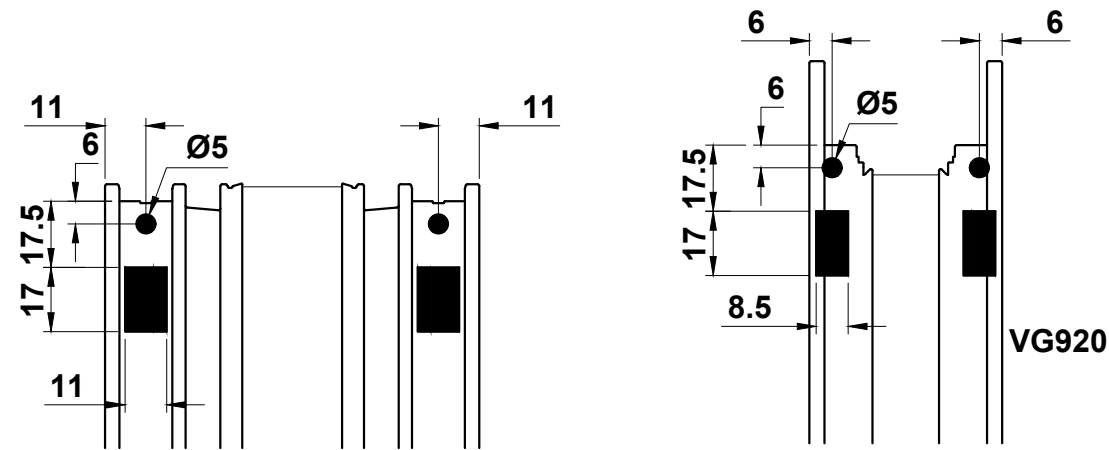
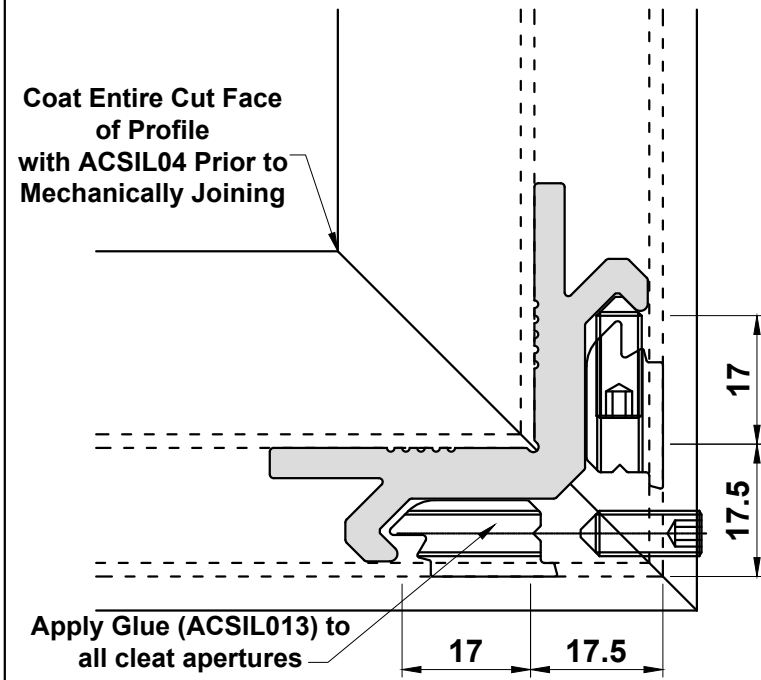
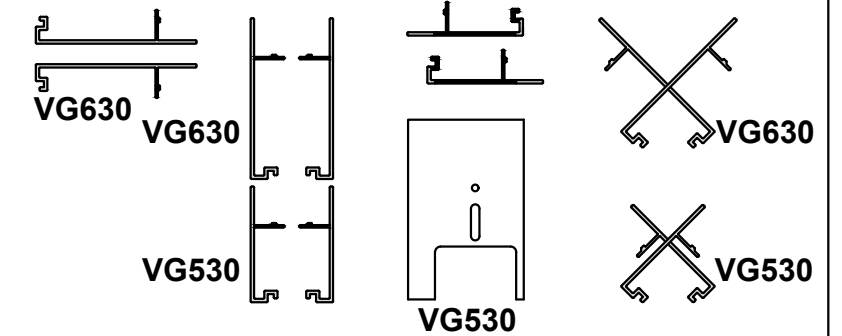
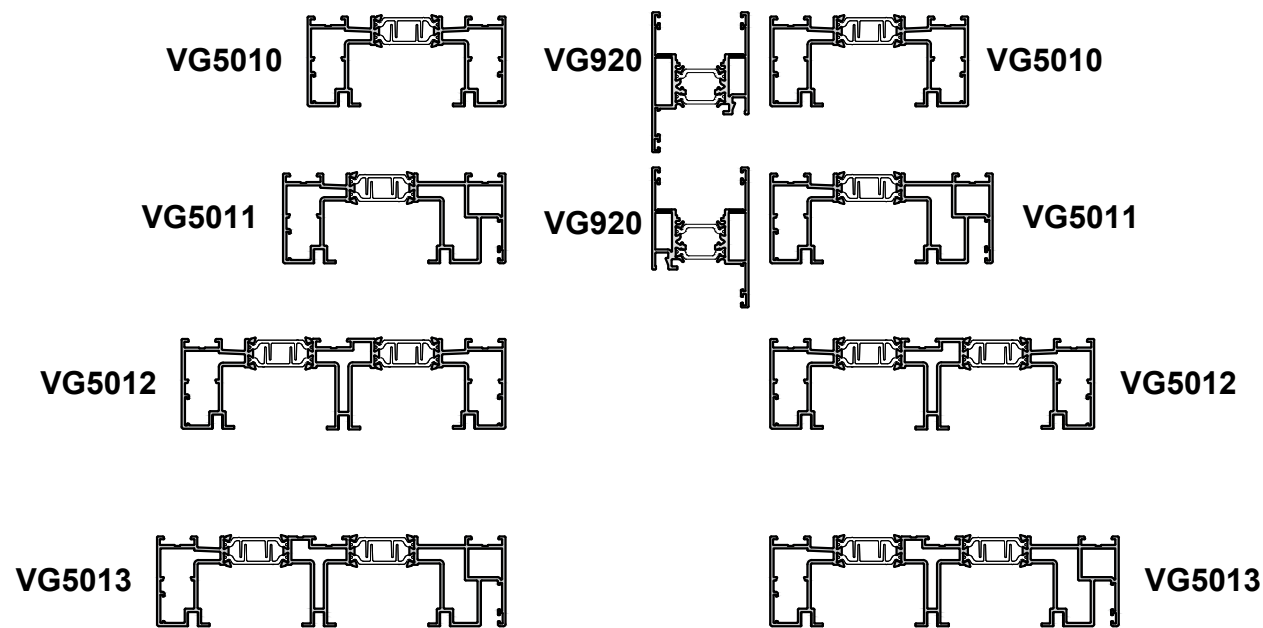
Please use this manual alongside the Visoglide Plus manual.



ACVG905N Punch Tool Sections



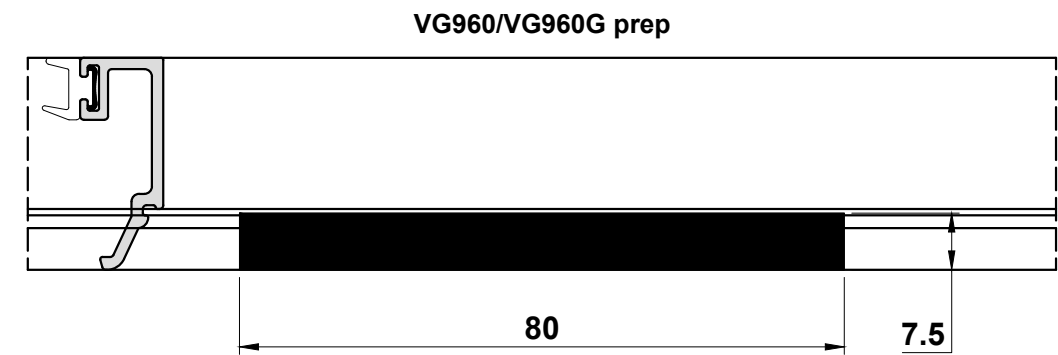
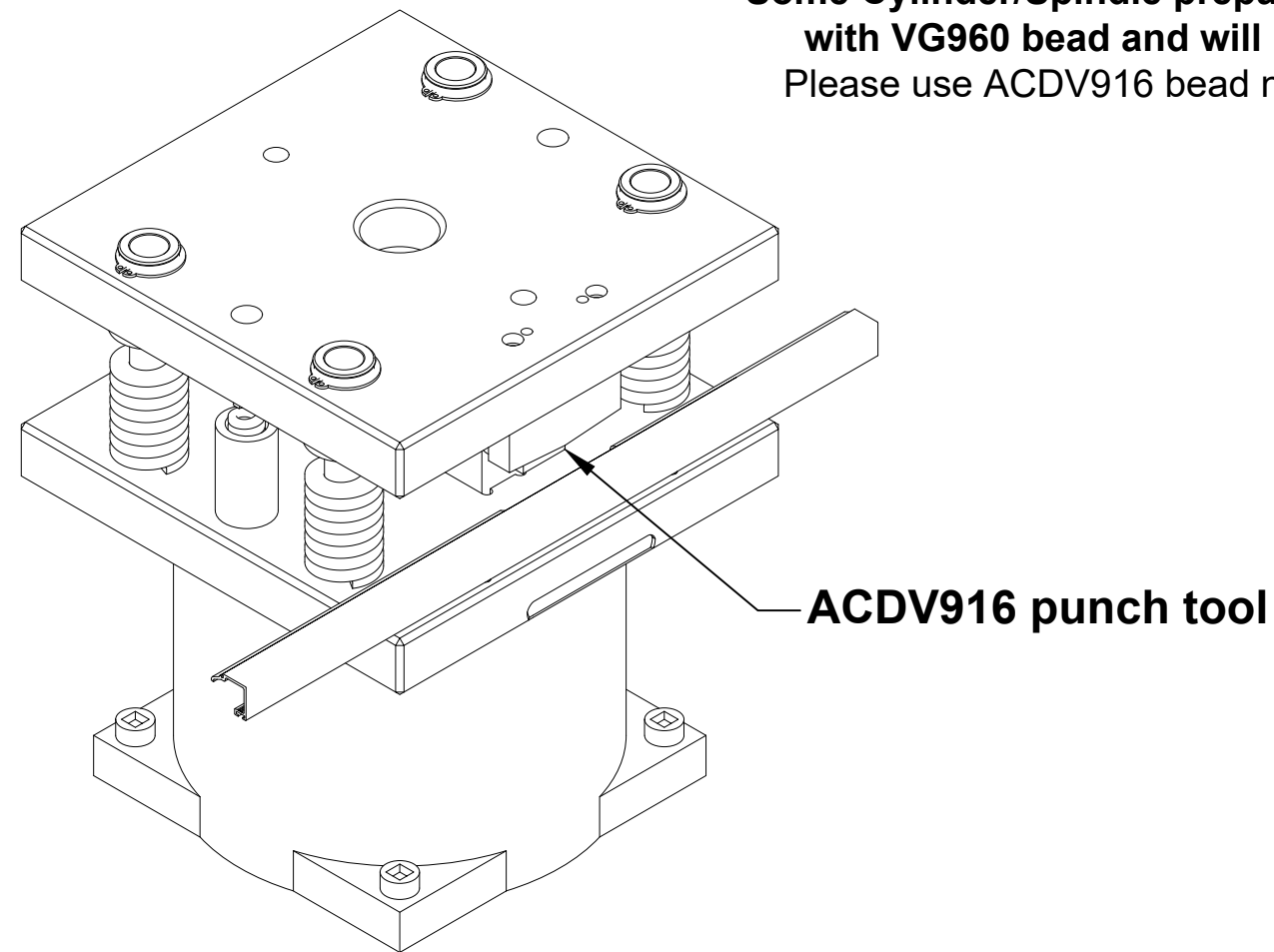
Please Note:
VG920 can only be punched using ACVG905N.



Do Not Scale From This Drawing

ACDV916 Punch Tool Sections

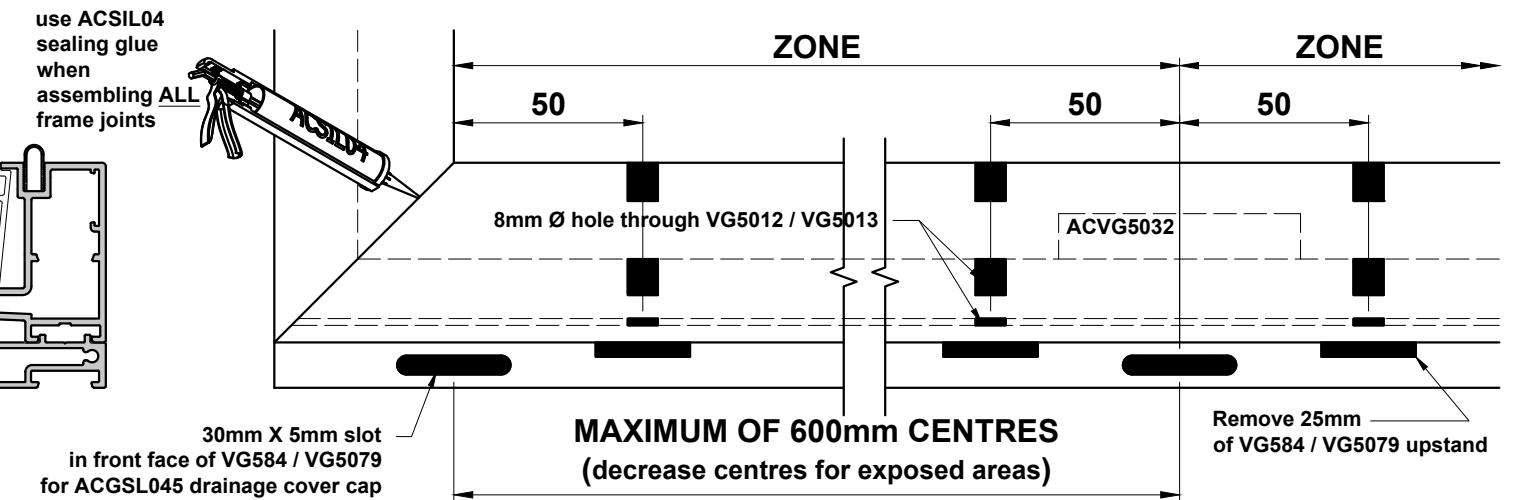
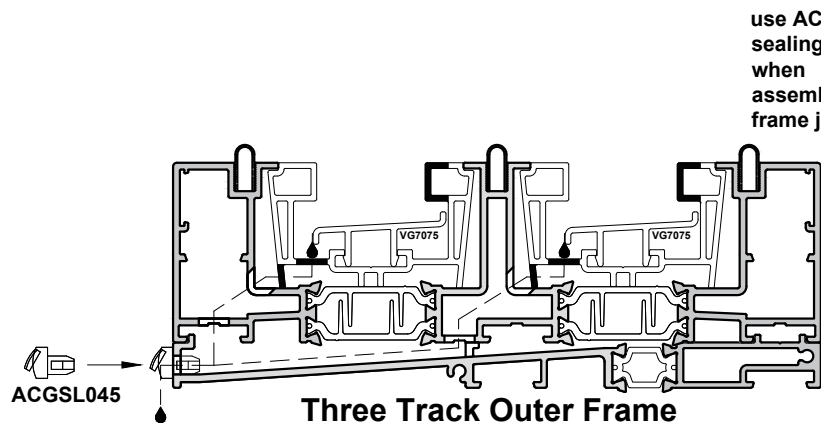
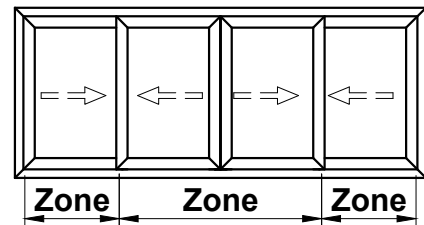
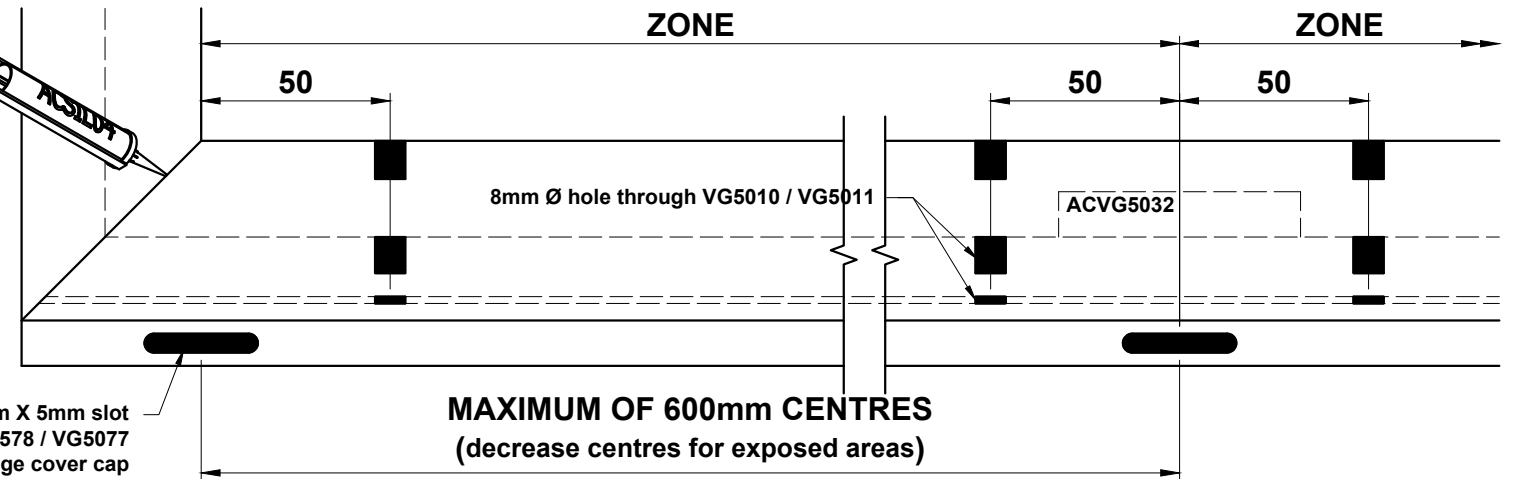
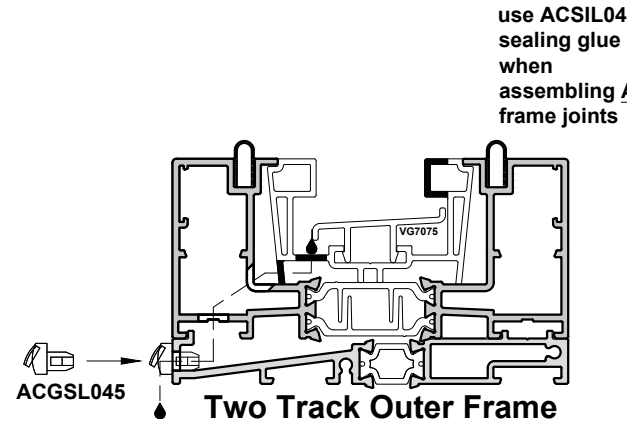
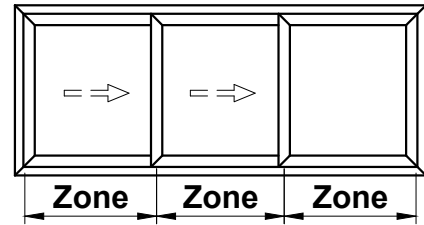
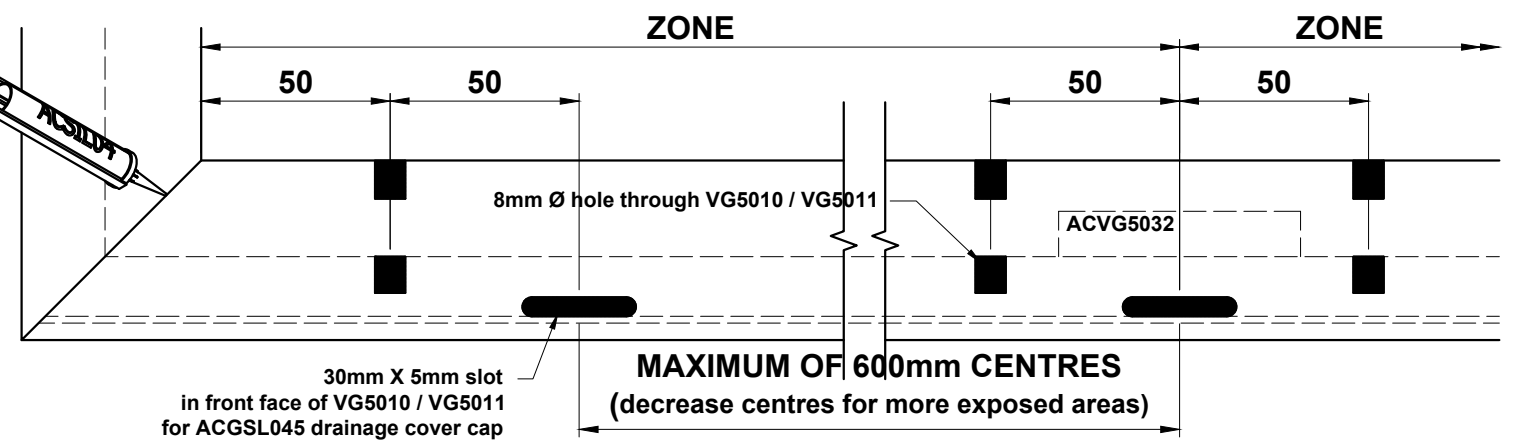
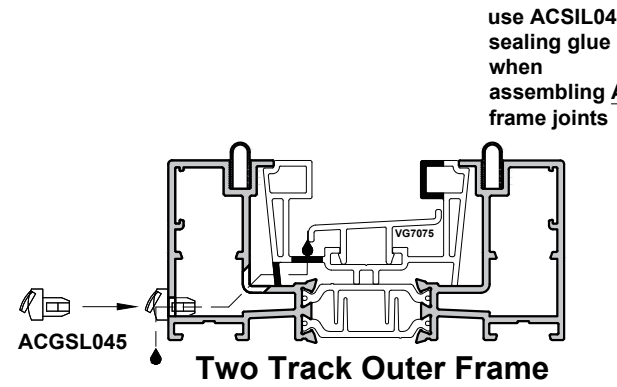
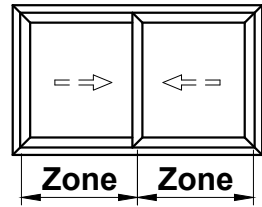
Some Cylinder/Spindle preparations will interfere with VG960 bead and will require notching.
Please use ACDV916 bead notching punch tool.



Please contact Technical Department for further information.

Do Not Scale From This Drawing

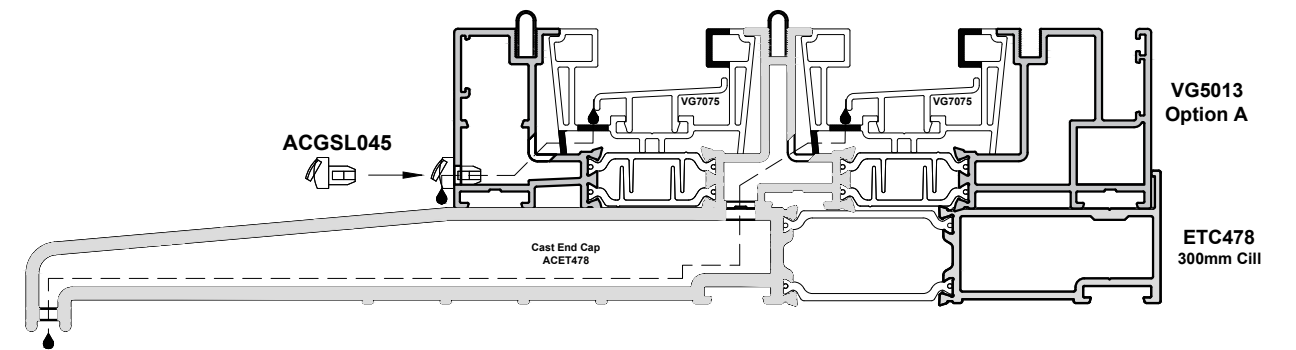
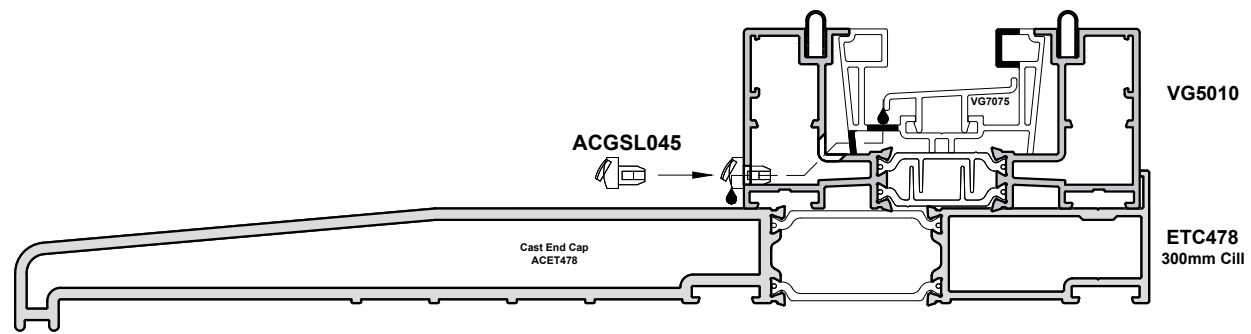
Outer Frame Drainage Details



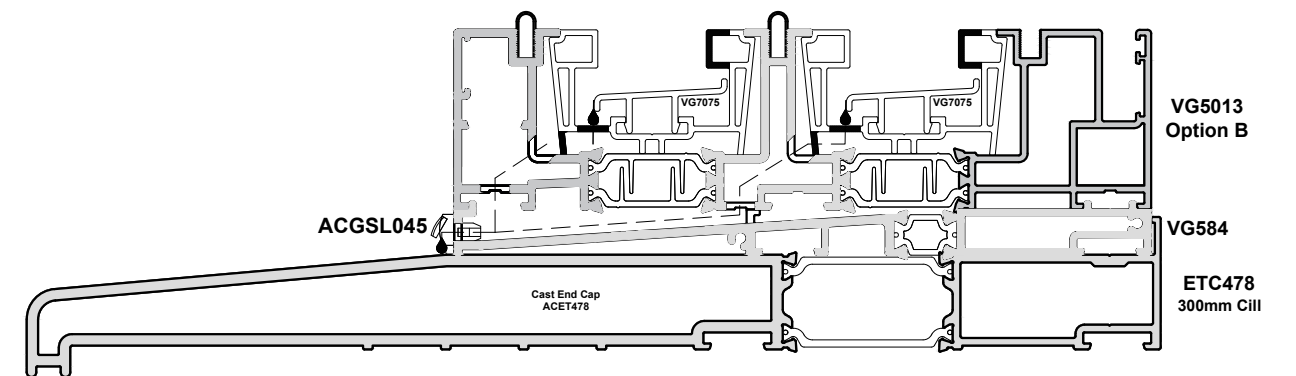
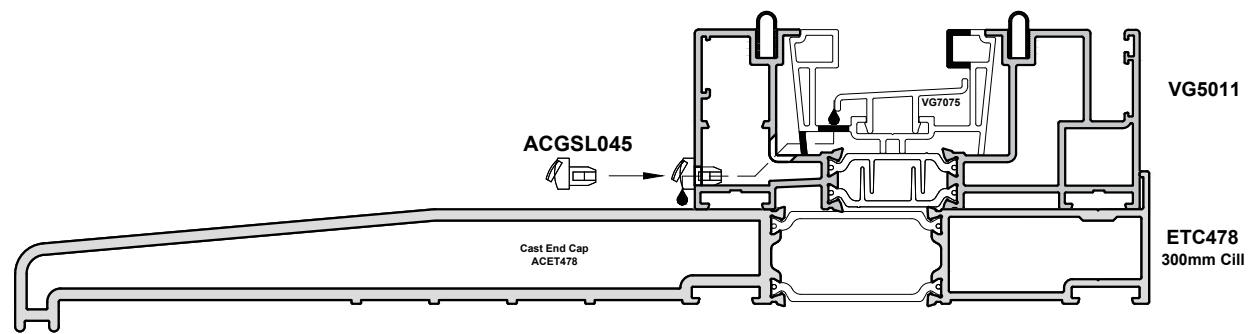
*After machining, all exposed aluminium should be coated using ACSIL014 or painted to match frame. (Consider all following sheets where machining occurs)

Do Not Scale From This Drawing

IMPORTANT NOTE: VG5012 CAN ONLY BE USED WITH THE VG5079 FLUSH DRAINAGE TRAY

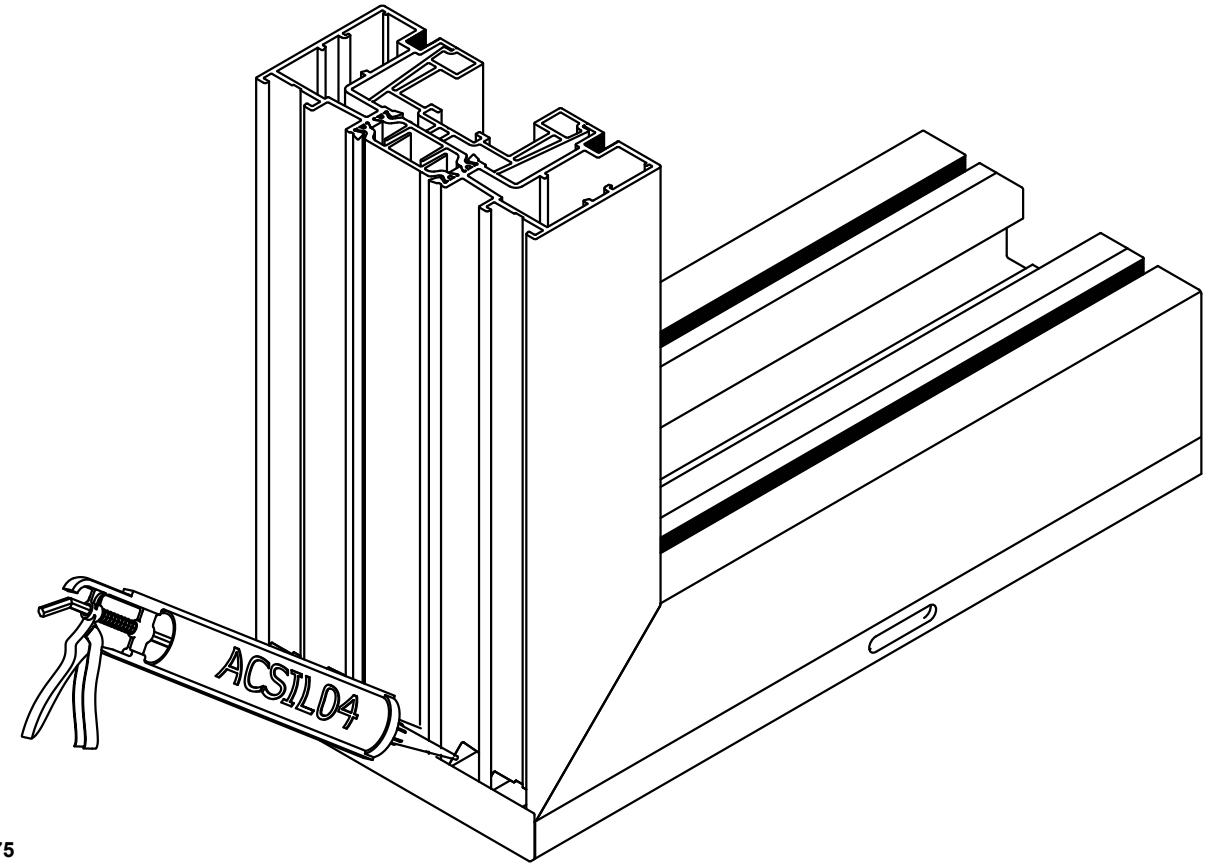
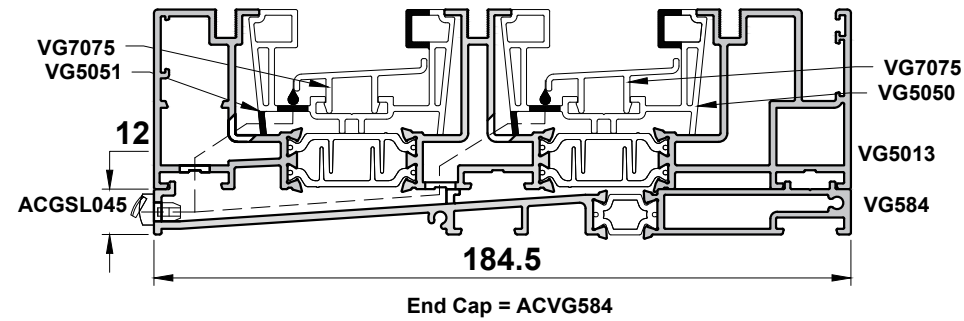
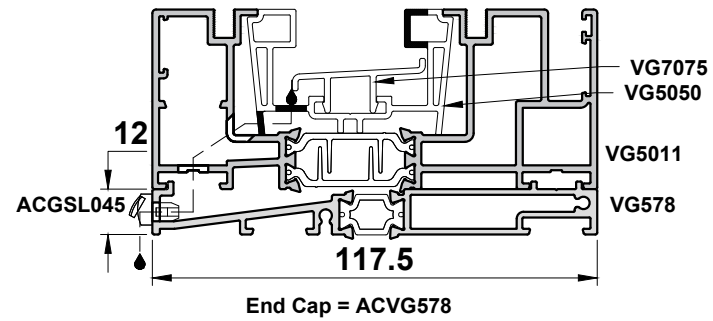
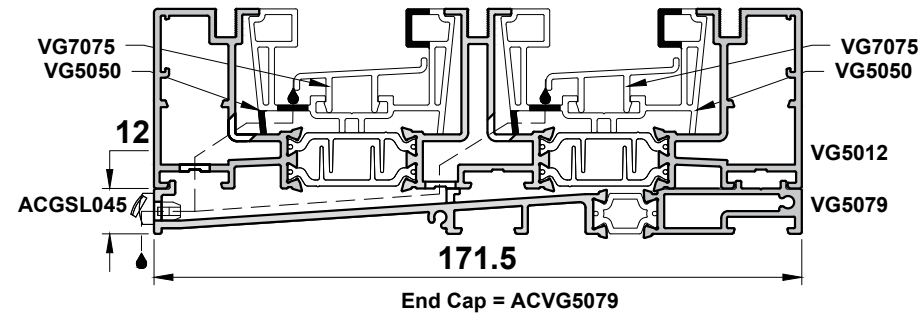
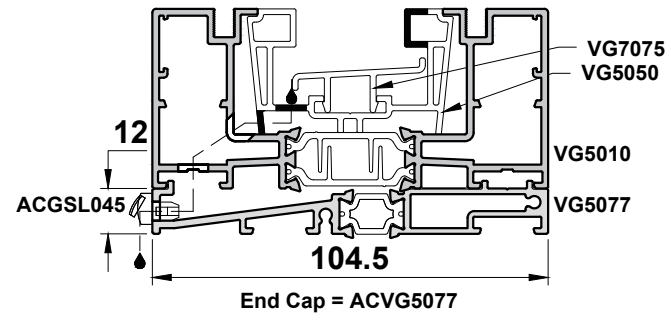


**Important Fabrication Notes:
Use the drainage spacings shown on page E06**

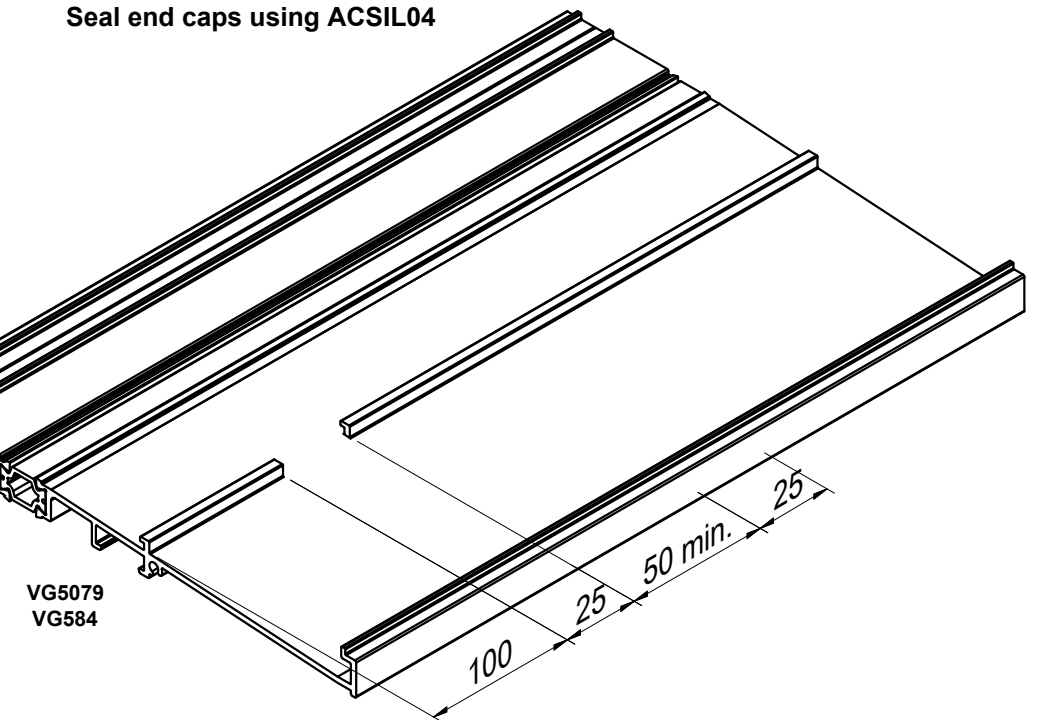


Do Not Scale From This Drawing

Flush Drainage Tray Details

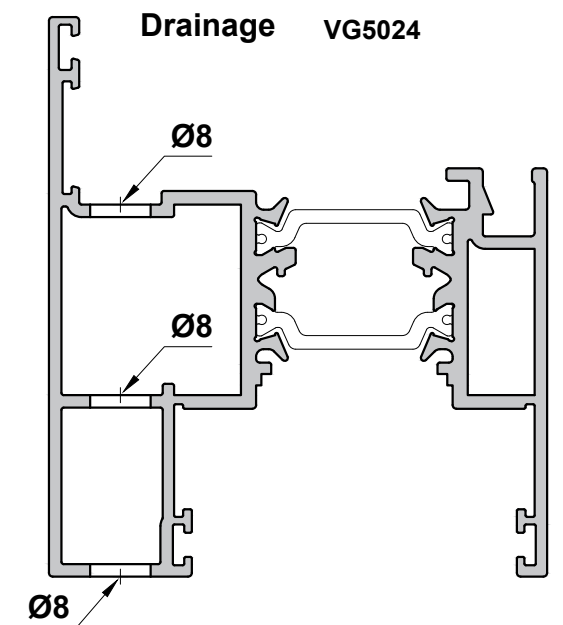
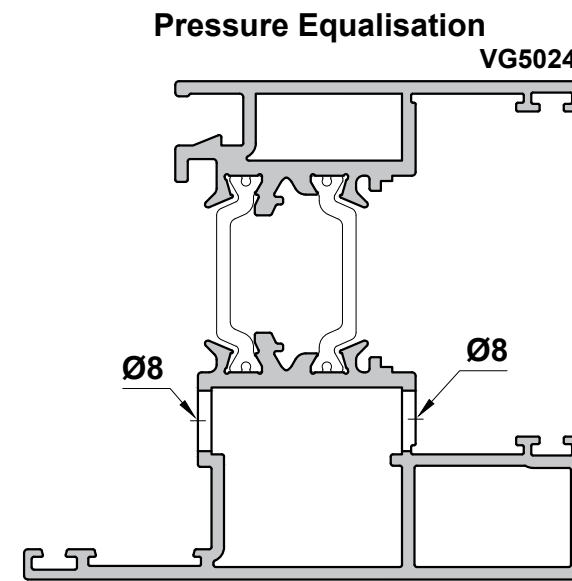
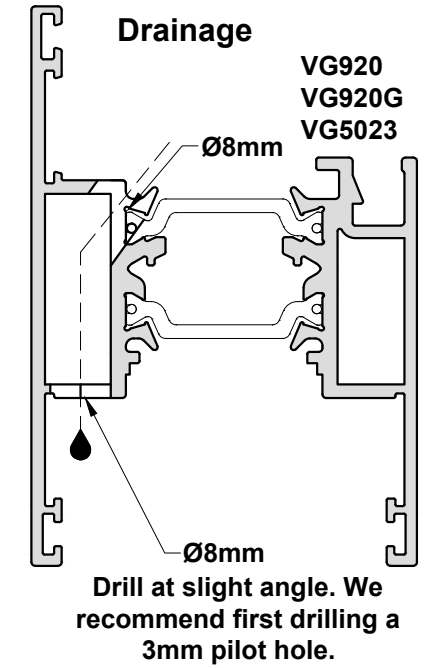
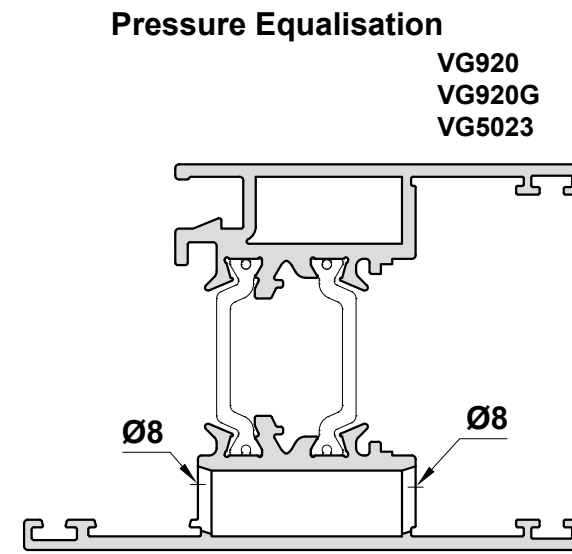
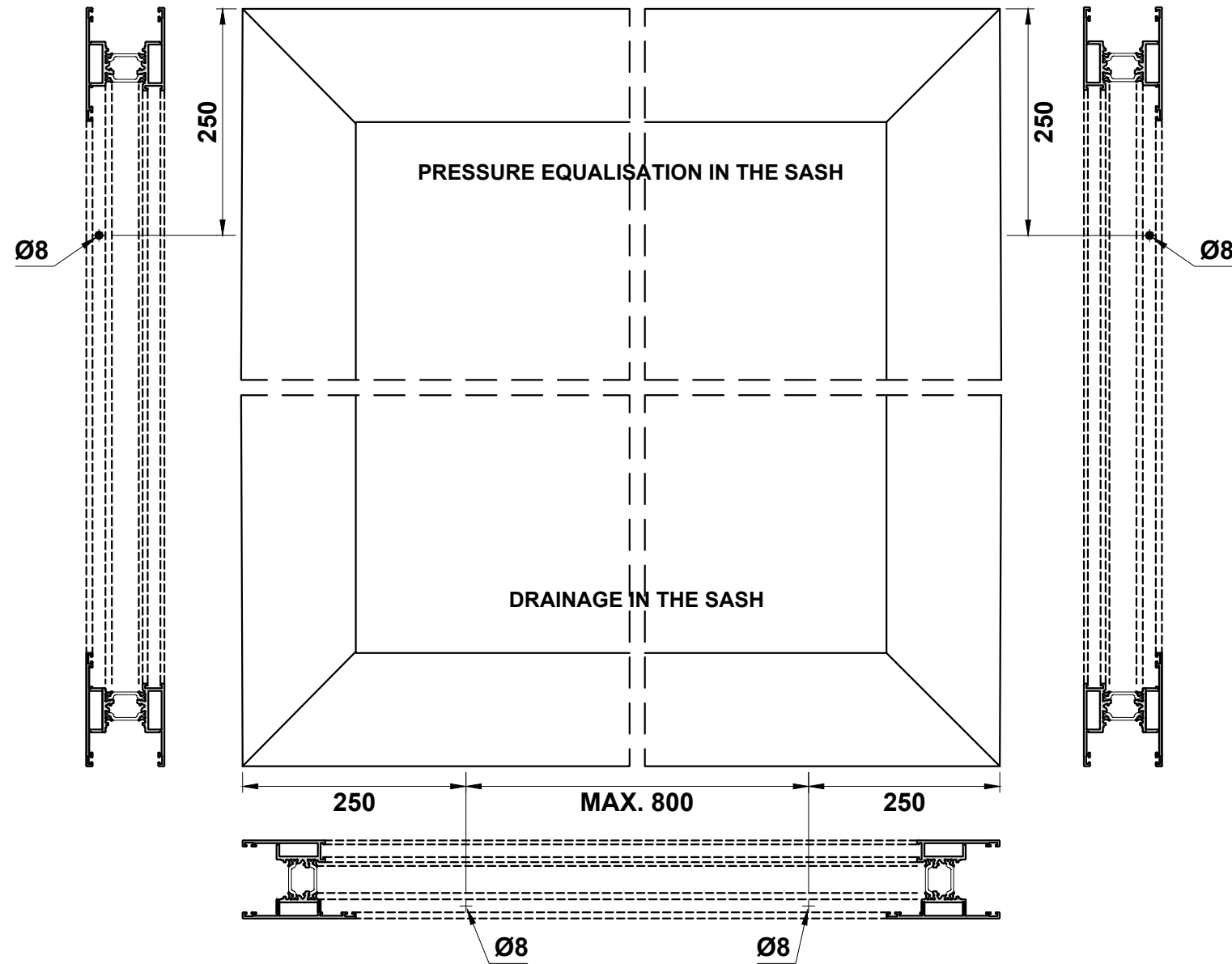


Seal end caps using ACSIL04



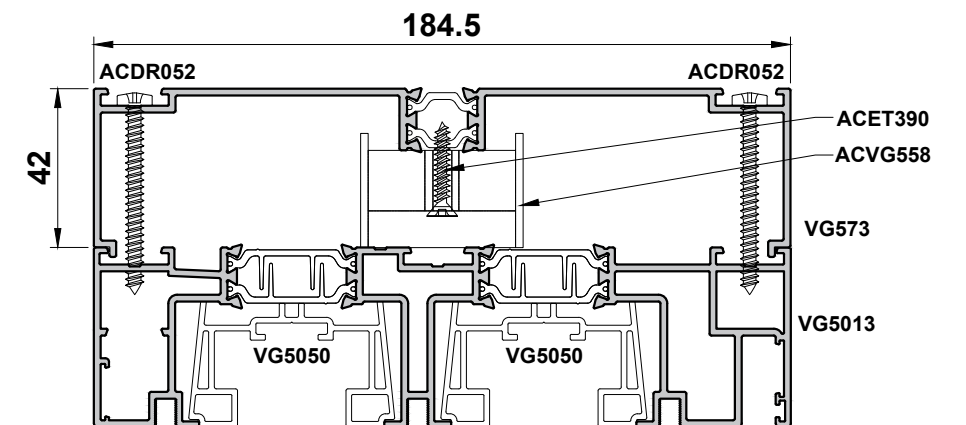
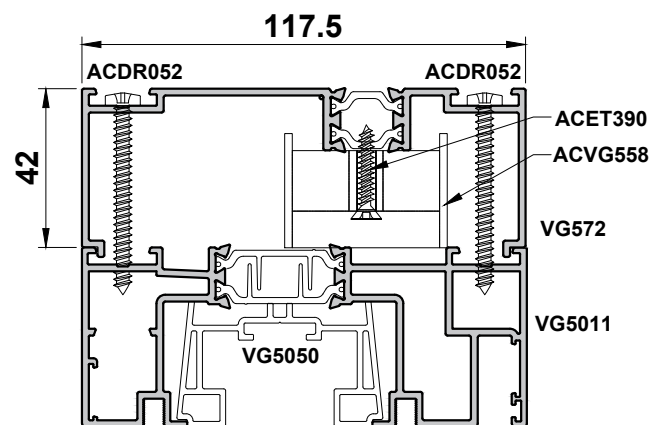
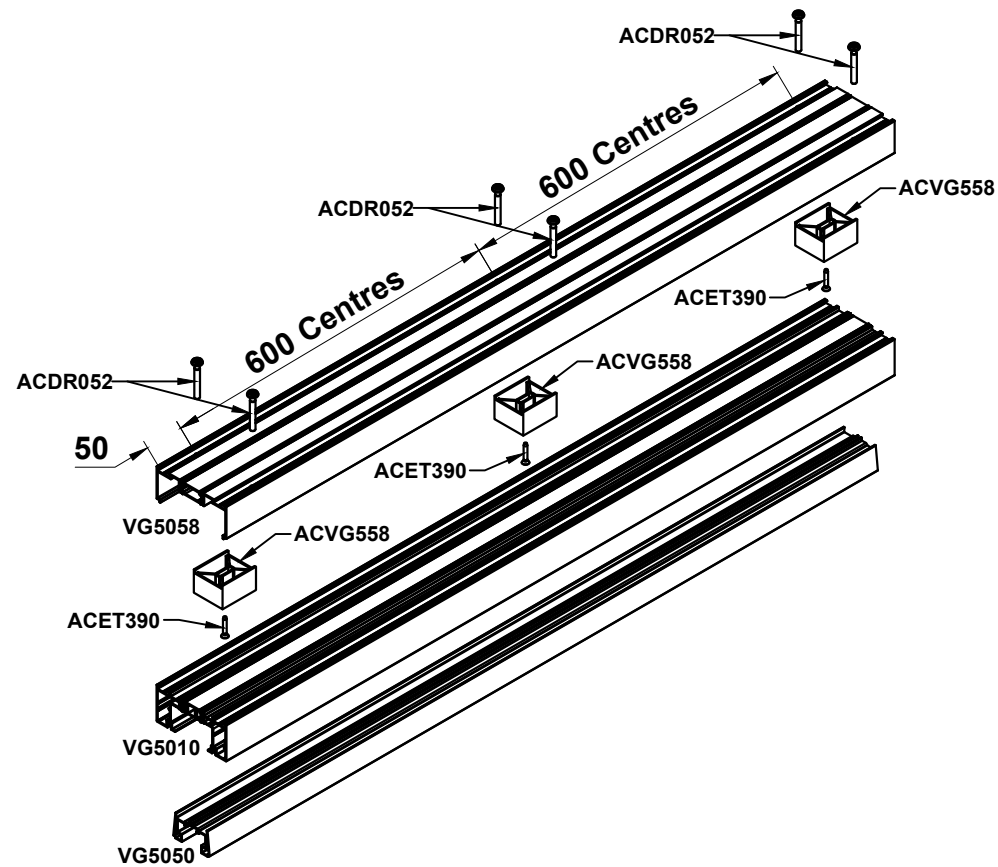
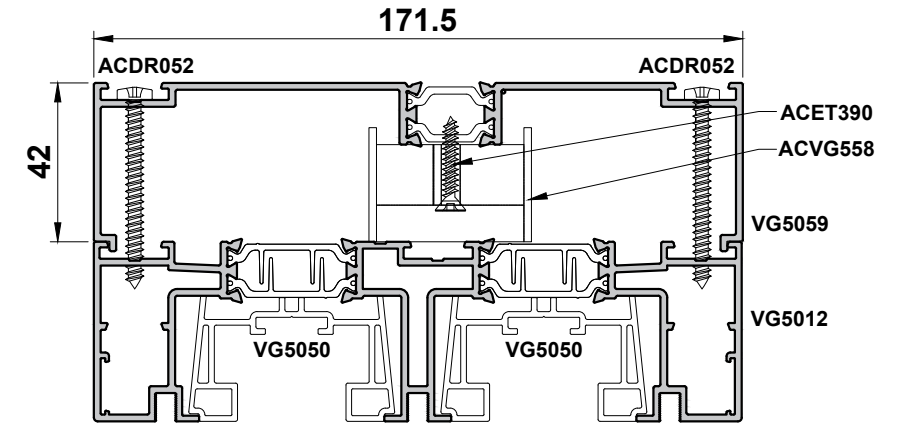
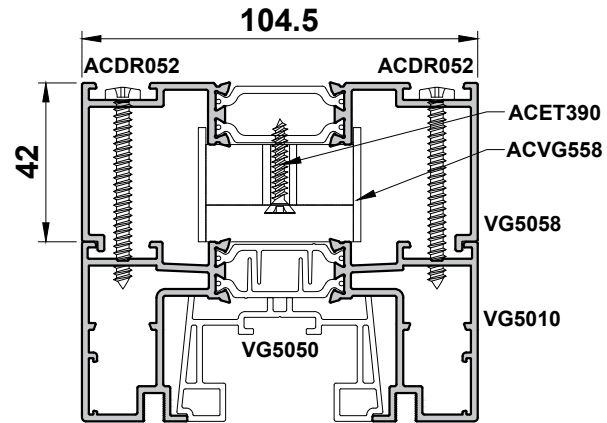
Do Not Scale From This Drawing

Sash Drainage & Pressure Equalisation



Do Not Scale From This Drawing

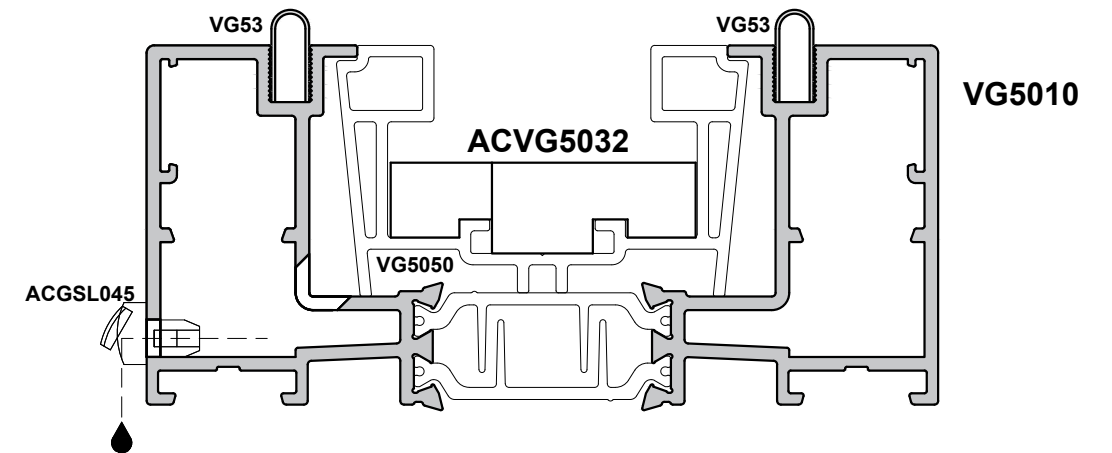
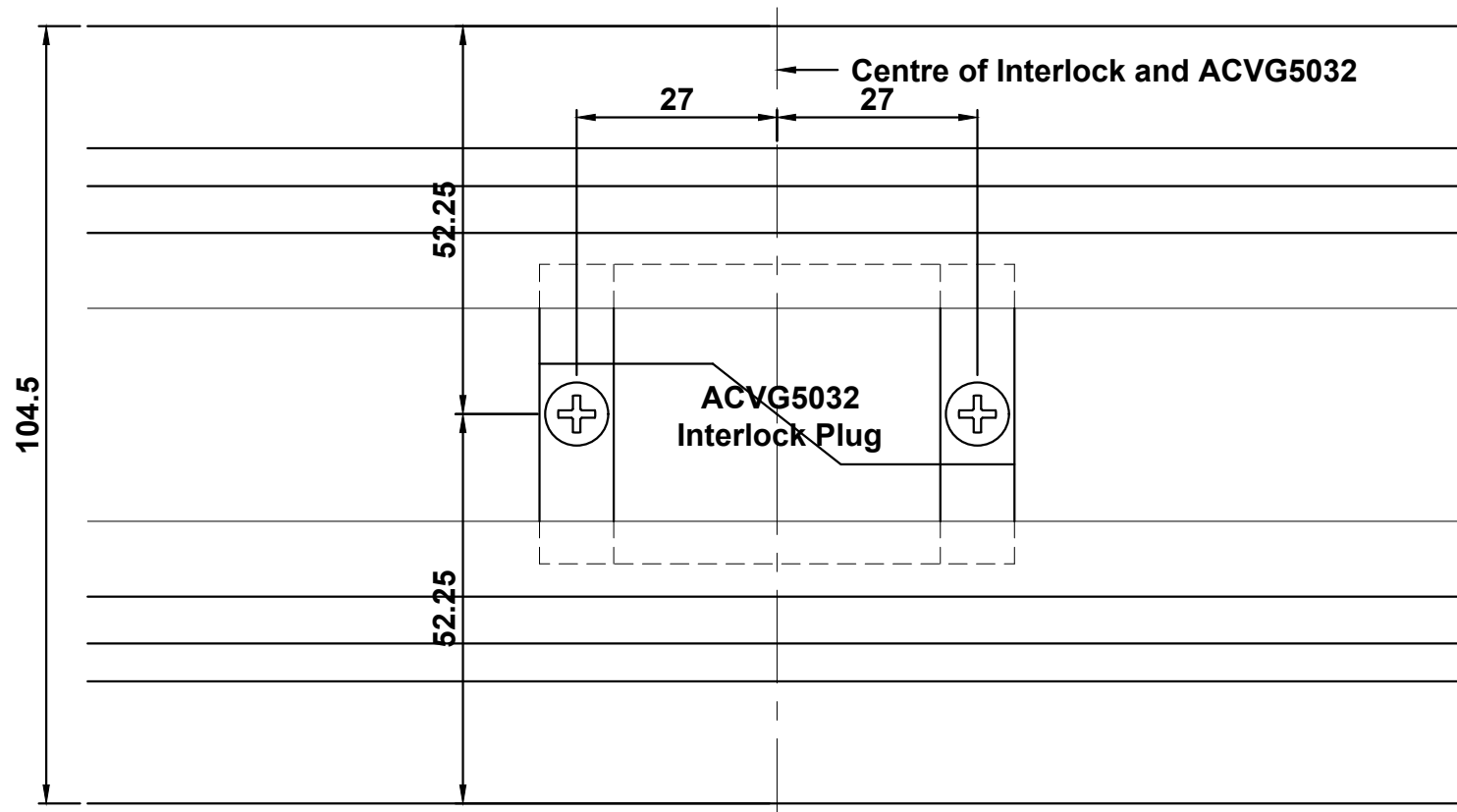
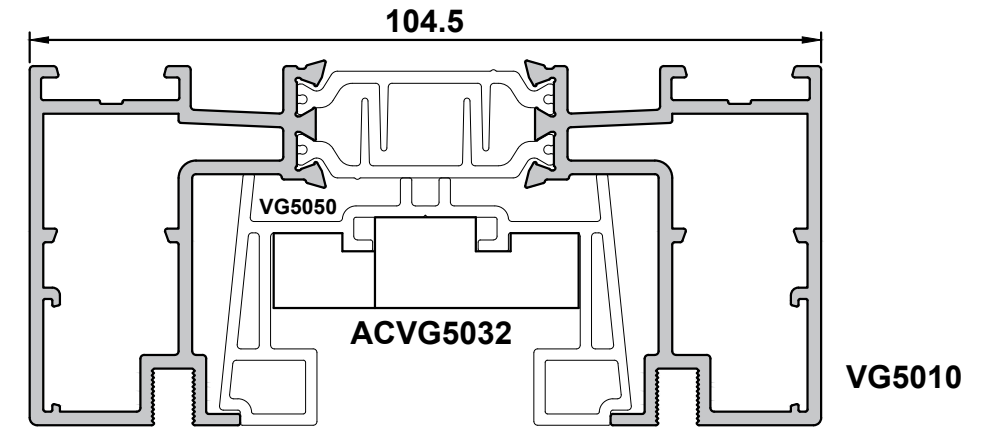
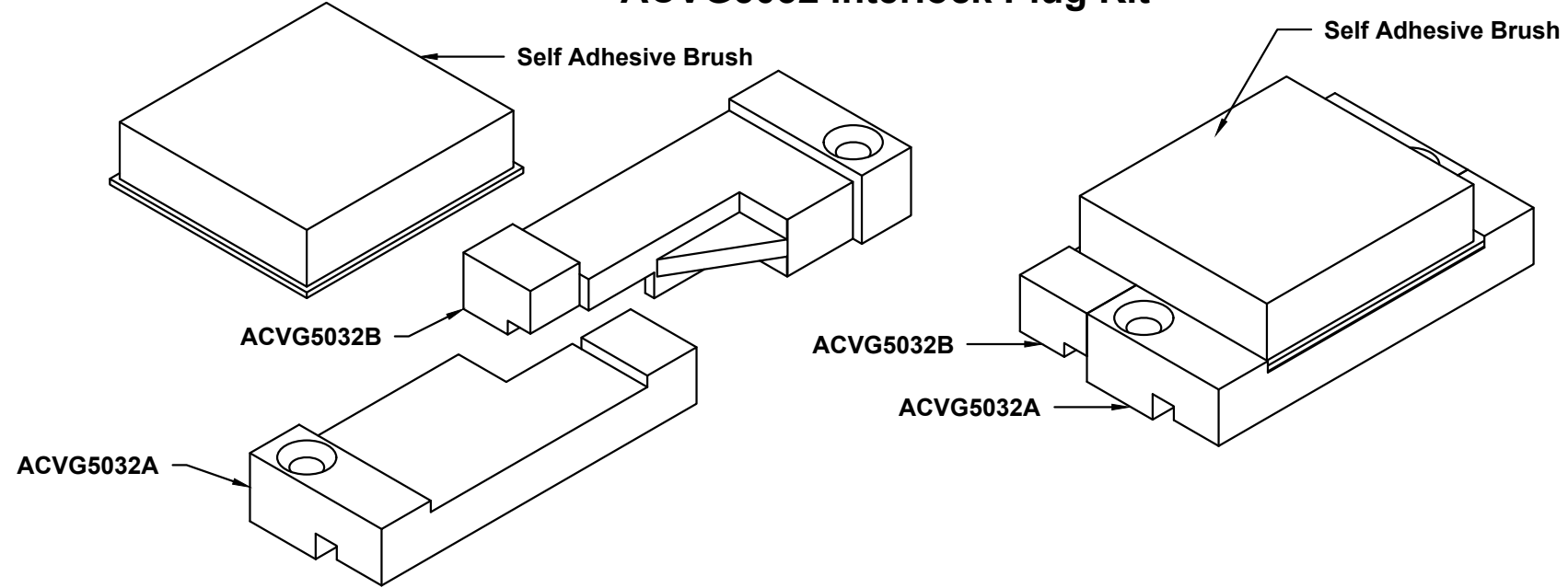
Head Extension Fitting Details



Do Not Scale From This Drawing

Interlock Plug Details

ACVG5032 Interlock Plug Kit

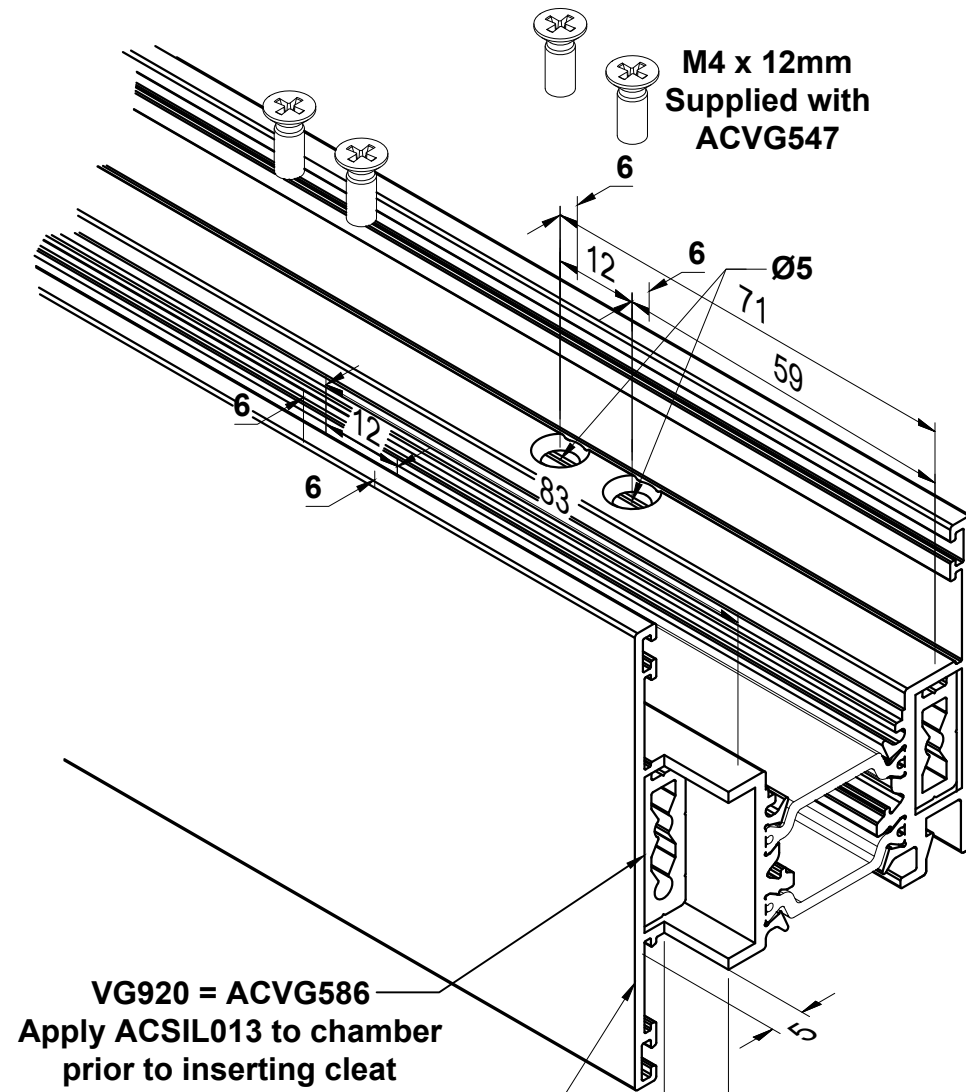


Do Not Scale From This Drawing

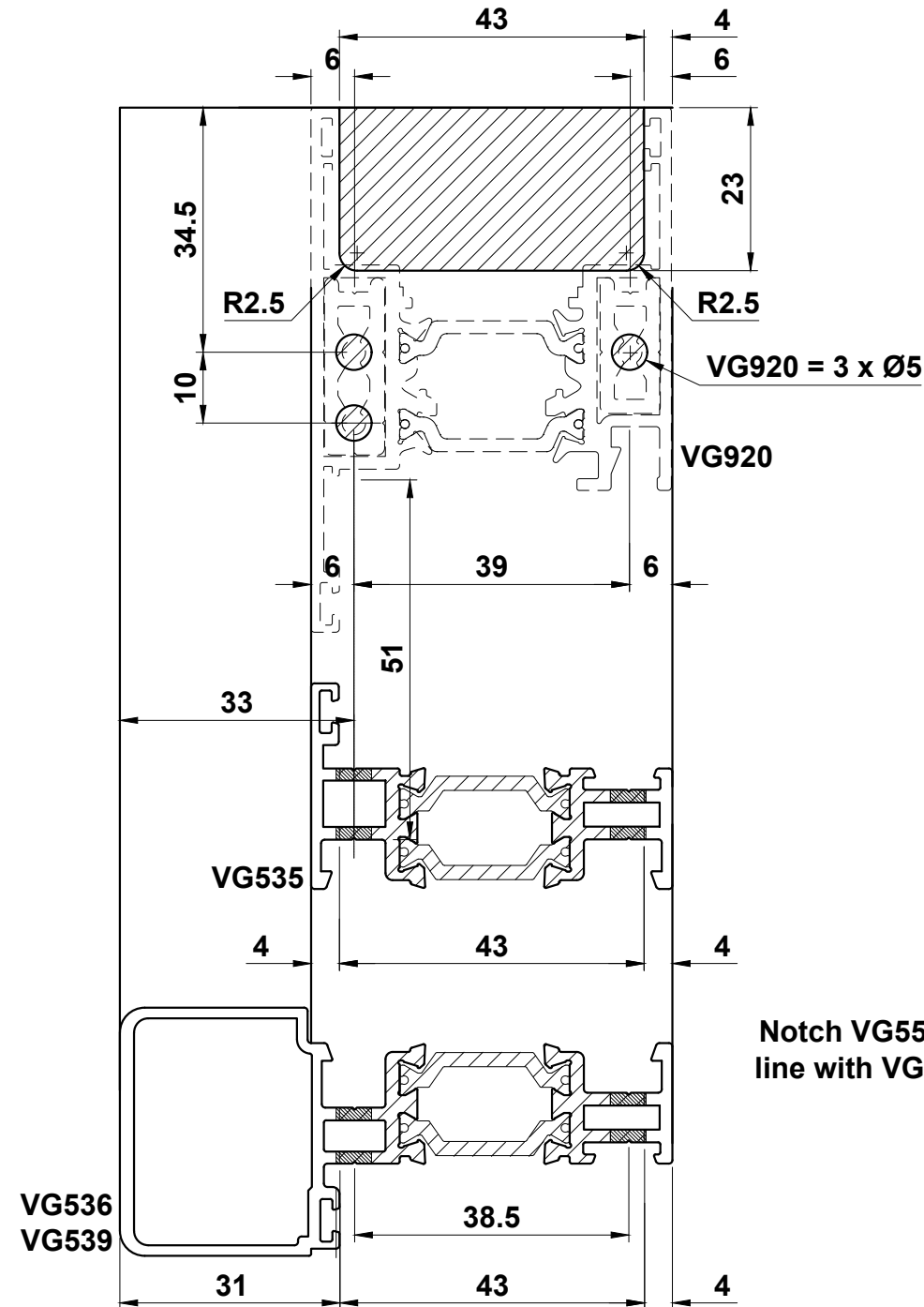
Slim Interlock Details

IMPORTANT NOTE: SLIM INTERLOCK IS NOT COMPATIBLE WITH THE VG5023 OR VG5024 SASH

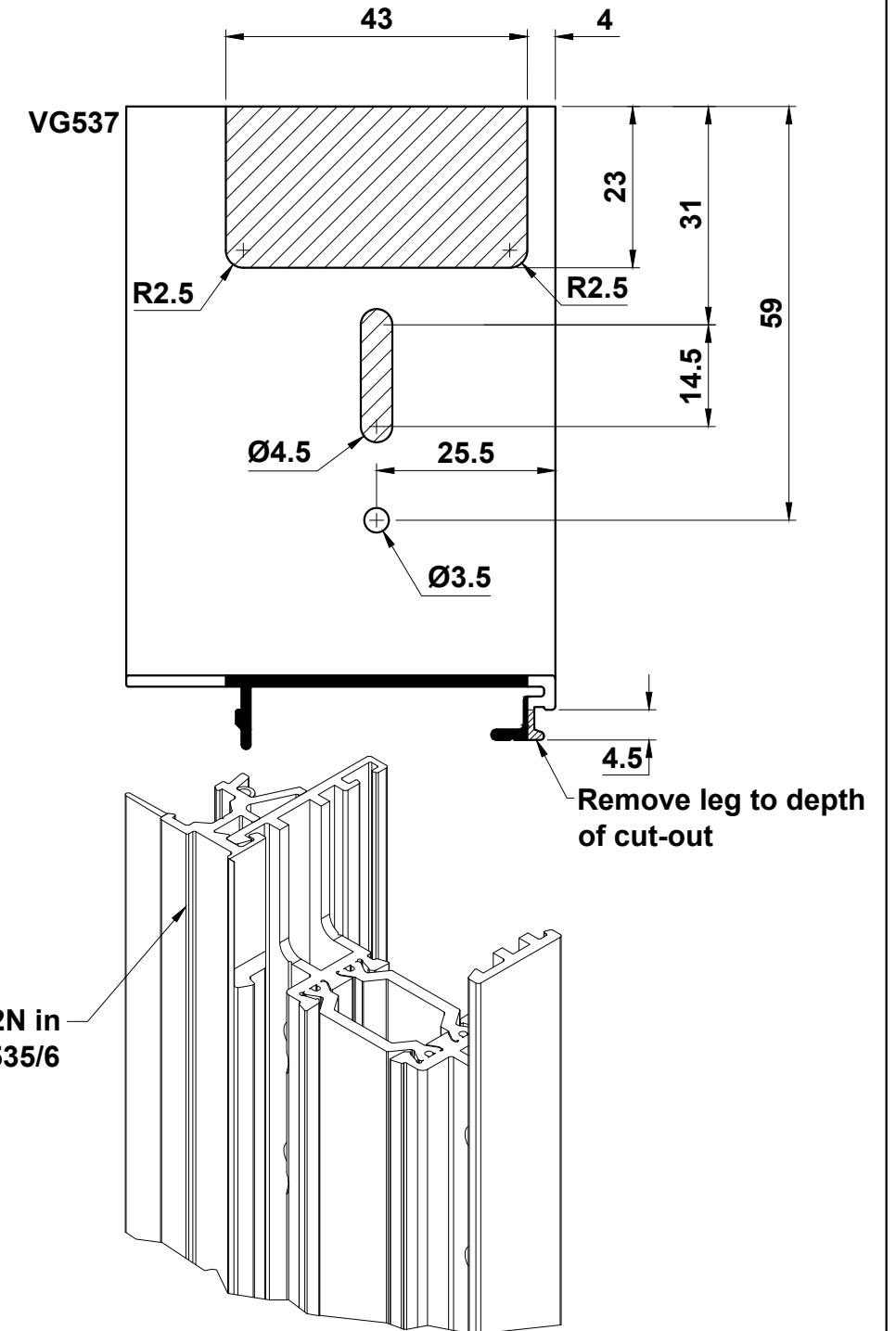
VG920 Preparation



Slim Interlock Stile Preparation



Slim Interlock Cover Cap Preparation



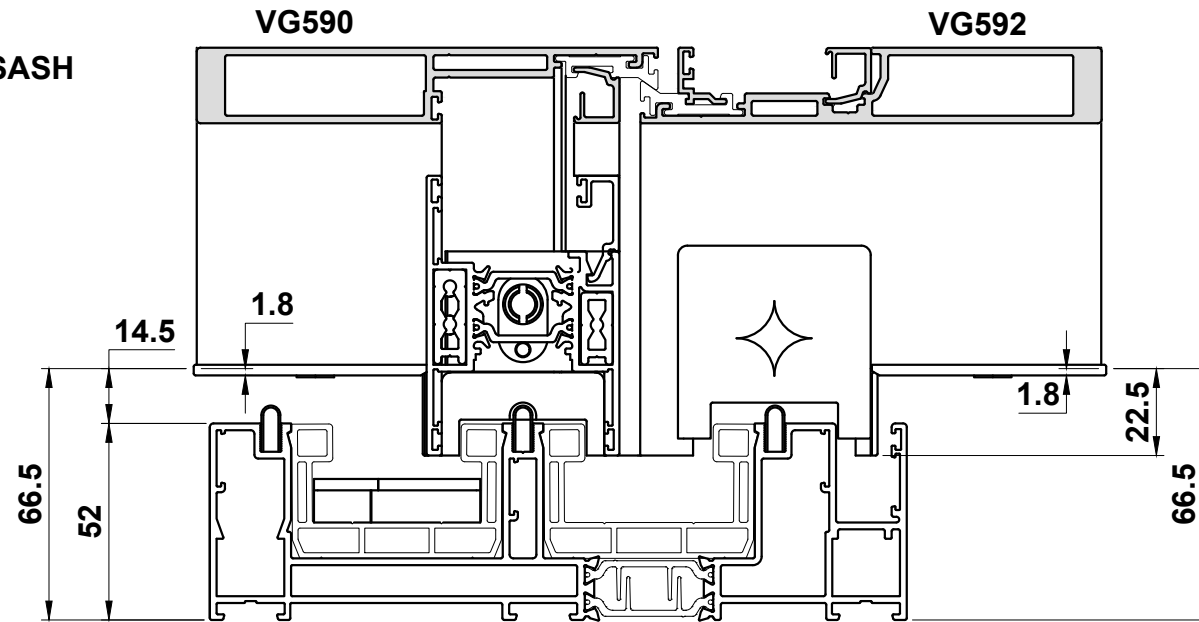
End Mill
Coat Entire Cut Face of Profile
with ACSIL04 Prior to
Mechanically Joining

Important Fabrication Note:
Please ensure bottom joint is
fully sealed after assembly
using ACSIL04.

Do Not Scale From This Drawing

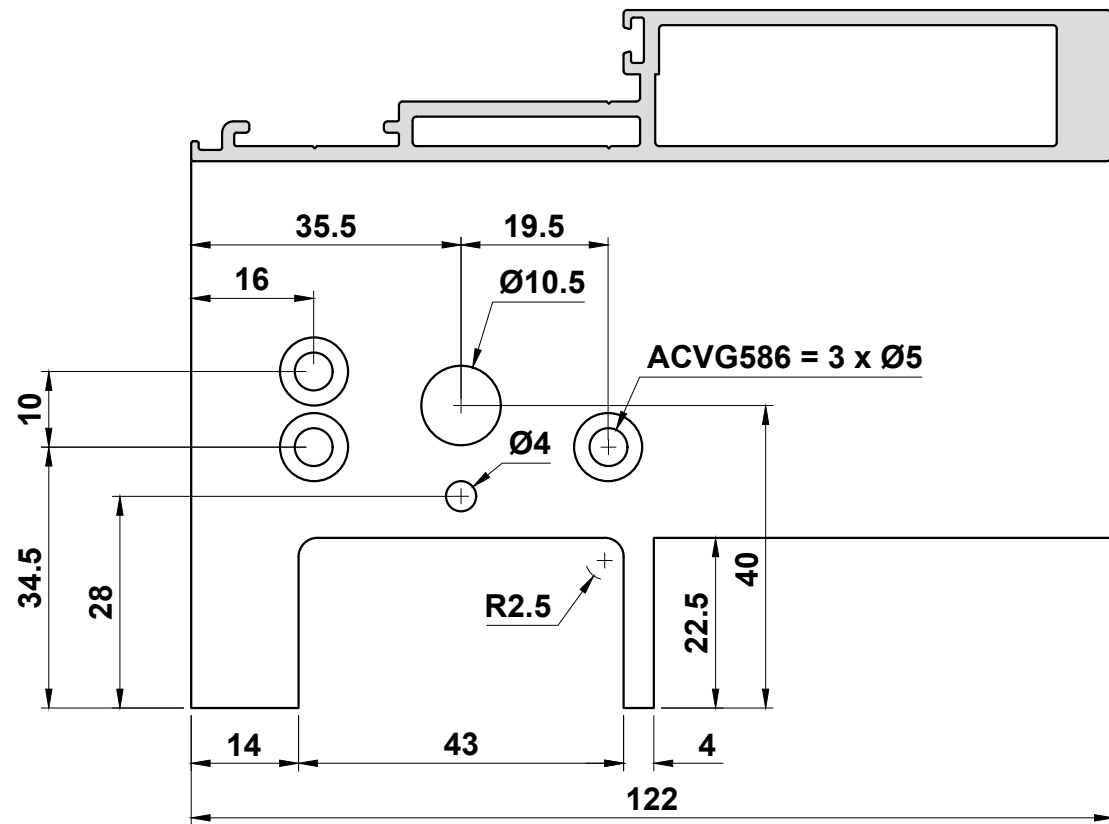
VG590 & VG592 Preparation with VG920

IMPORTANT NOTE:
SLIM INTERLOCK IS NOT COMPATIBLE WITH THE VG5023 OR VG5024 SASH

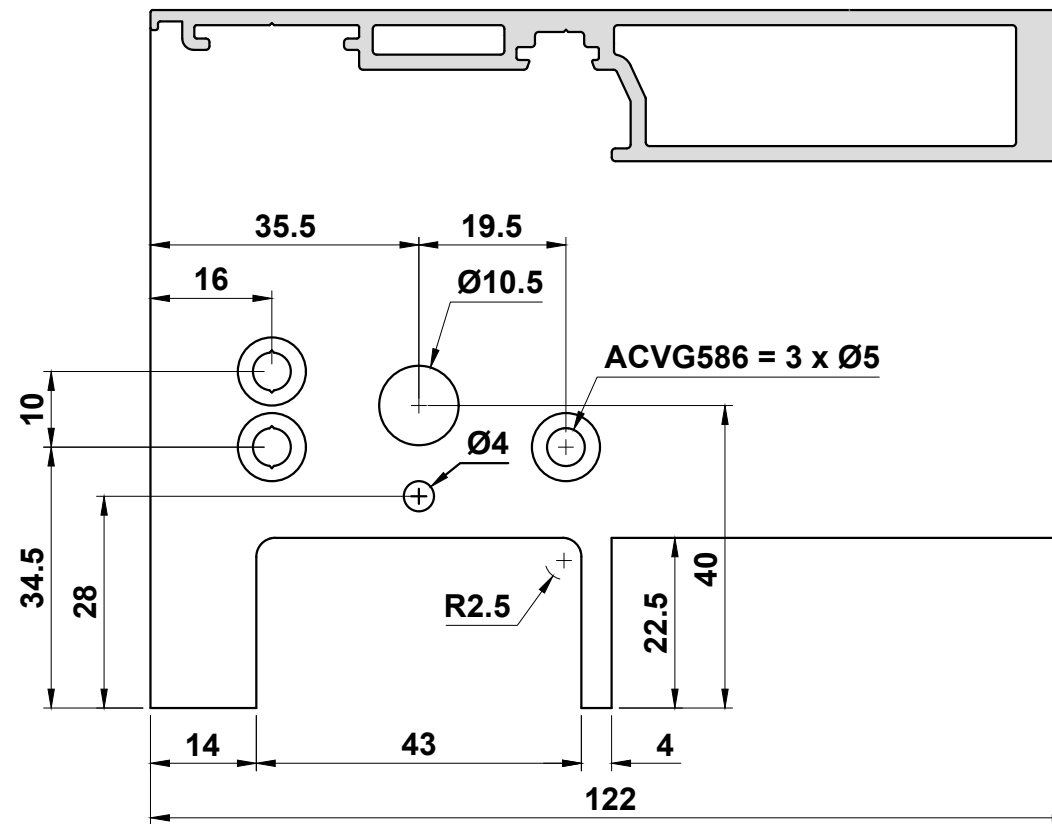


Note
Prepare VG596 using ACVG596, then slide into VG590 & VG592.

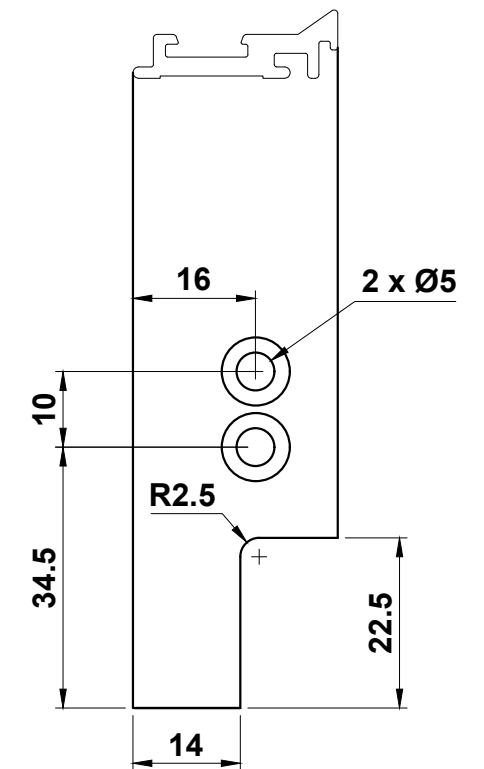
VG590 Preparation (Top & bottom)



VG592 Preparation (Top & bottom)

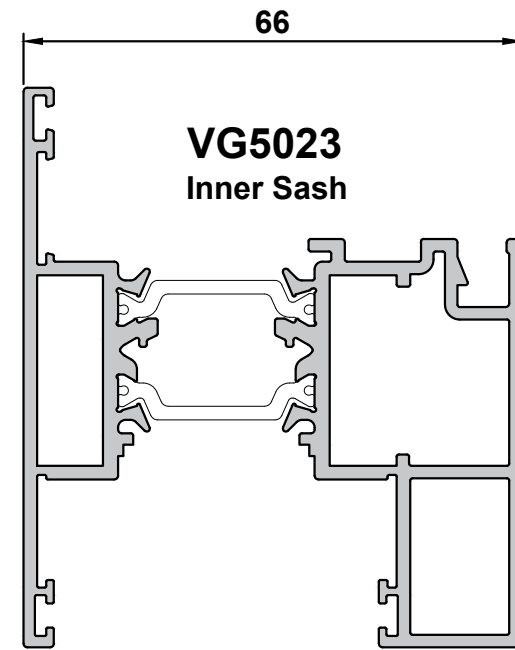
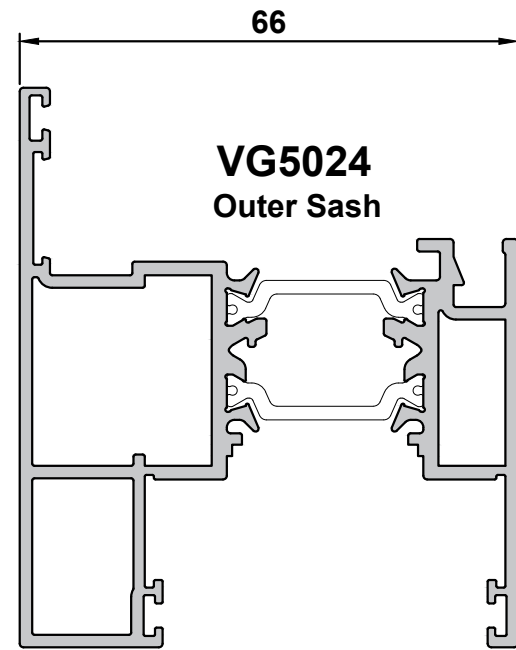


VG596 Preparation (Top & bottom)



Do Not Scale From This Drawing

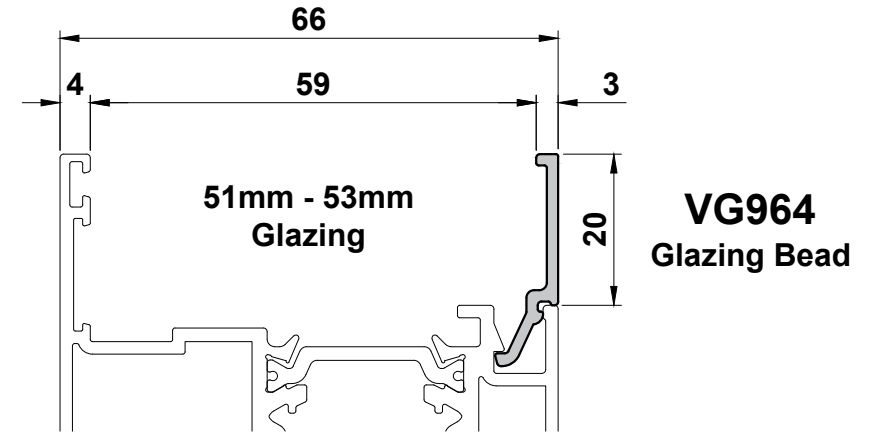
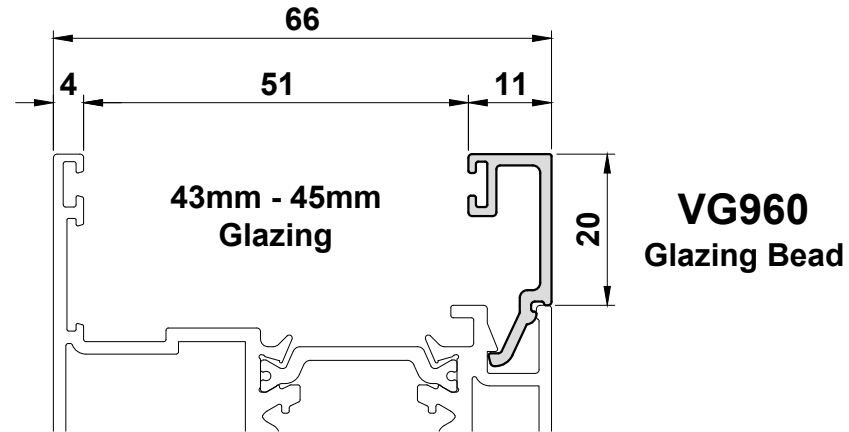
Glazing Options



 **ACET842**
3mm Retained gasket

 **ACW20038**
4 / 3mm Tear-off Wedge Gasket

 **ACET848**
5 / 4mm Tear-off Wedge Gasket

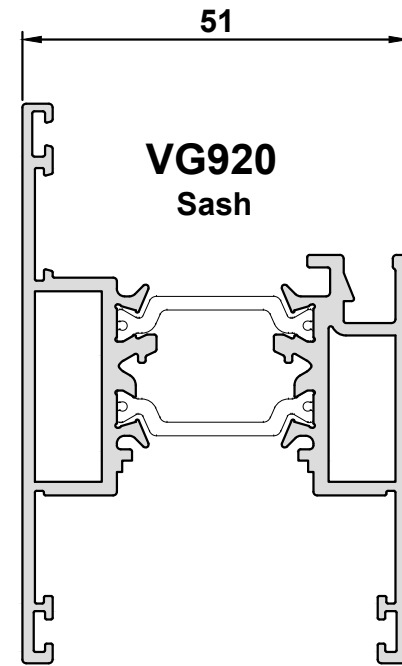


Standard Gaskets		
Glazing Thickness	External Gasket	Internal Gasket
43	ACET842	ACET848
44	ACET842	ACW20038
45	ACET842	ACW20038


Standard Gaskets		
Glazing Thickness	External Gasket	Internal Gasket
51	ACET842	ACET848
52	ACET842	ACW20038
53	ACET842	ACW20038

Do Not Scale From This Drawing

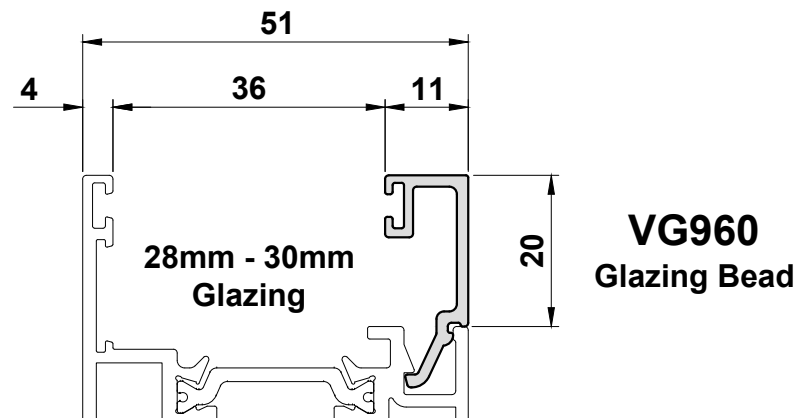
Glazing Options



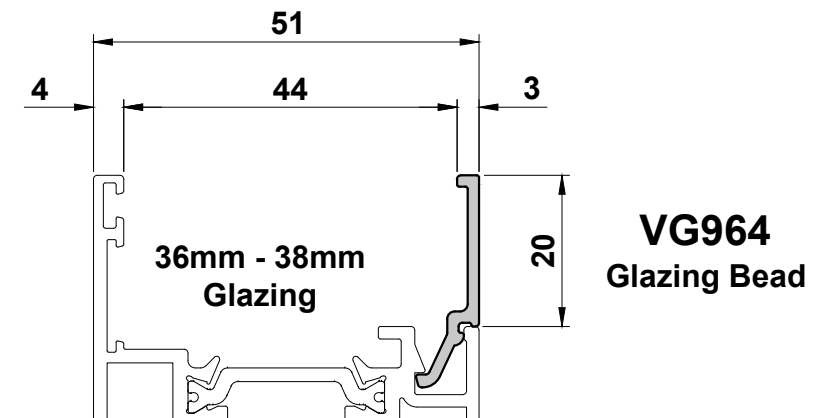
 **ACET842**
3mm Retained gasket

 **ACW20038**
4 / 3mm Tear-off Wedge Gasket

 **ACET848**
5 / 4mm Tear-off Wedge Gasket



Standard Gaskets		
Glazing Thickness	External Gasket	Internal Gasket
28	ACET842	ACET848
29	ACET842	ACW20038
30	ACET842	ACW20038



Standard Gaskets		
Glazing Thickness	External Gasket	Internal Gasket
36	ACET842	ACET848
37	ACET842	ACW20038
38	ACET842	ACW20038

Do Not Scale From This Drawing

Section F

Sawing Tables

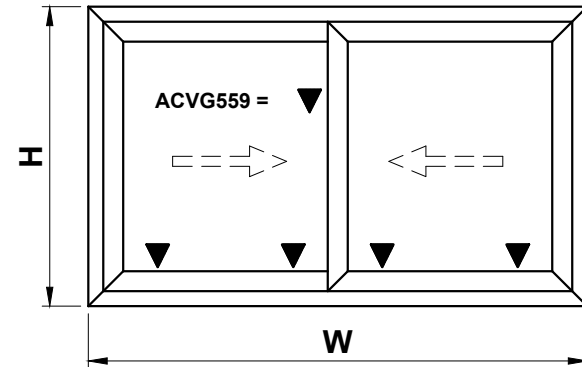
Sliding Doors..... F03 - F06

Section F

Cutting Information - Sliding VG5023 & VG5024 Sash

IMPORTANT NOTE:

Maximum Sash Weights:
Sliding Sashes = 250kg



GLASS SIZE	
2x	(W÷2) - 124.5 H - 196

PROFILES

VG5010 (with VG5050)		2		W
VG5010 (with VG5050)		2		H
VG5023		2		(W÷2) - 6.5
VG5023		2		H - 78
VG5024		2		(W÷2) - 6.5
VG5024		2		H - 78
VG530		2		H - 78
VG551R		2		H - 78
VG586		2		H - 78
BEAD		4		(W÷2) - 114.5
BEAD		4		H - 226
VG52		2		W - 95
VG52		4		H - 95
VG53		2		W - 95
VG7075		2		(W÷2) - 56.5

OPTIONAL

VL72		1		W - 9
VG5014		1		(W÷2) - 89
VG5014		1		H - 98

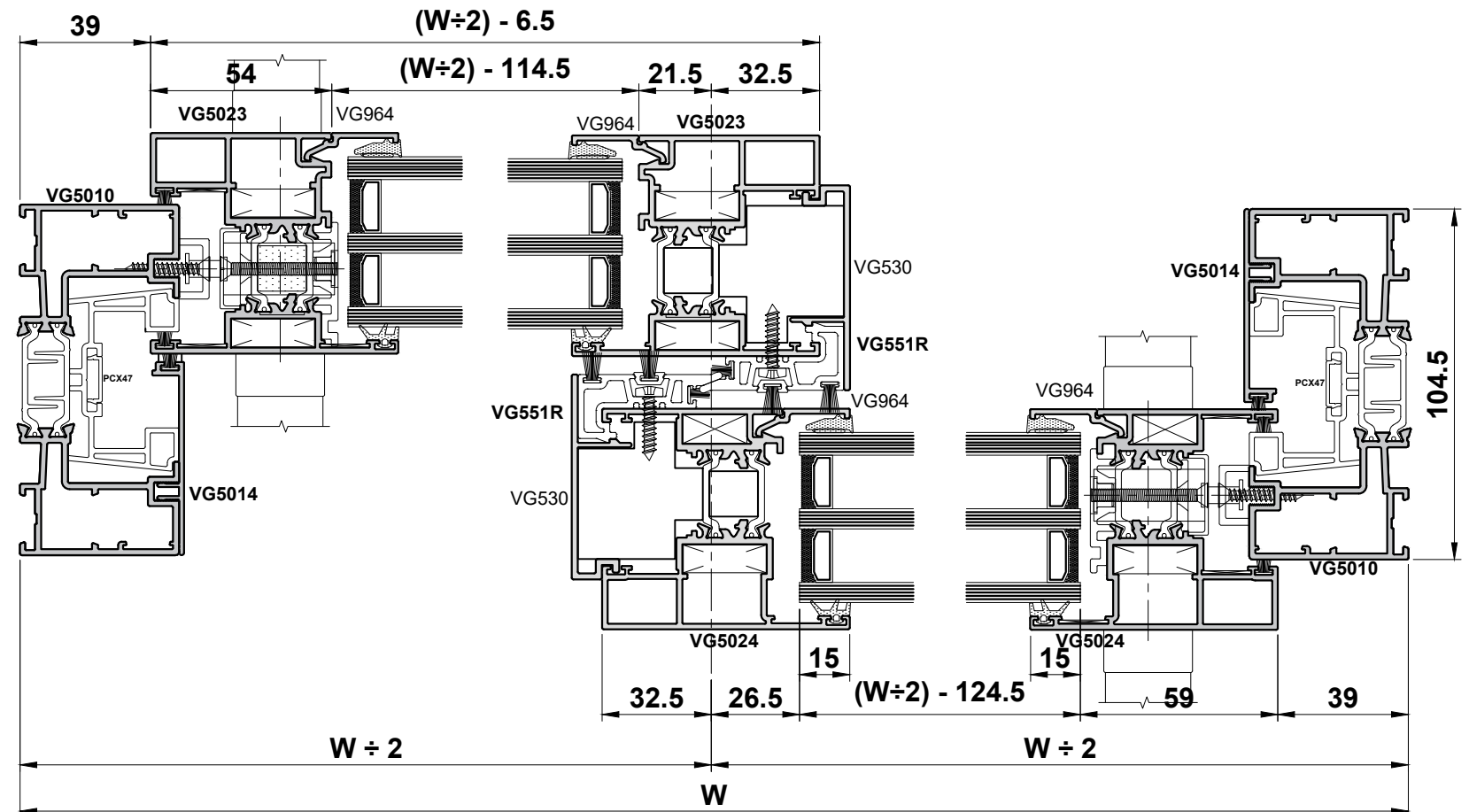
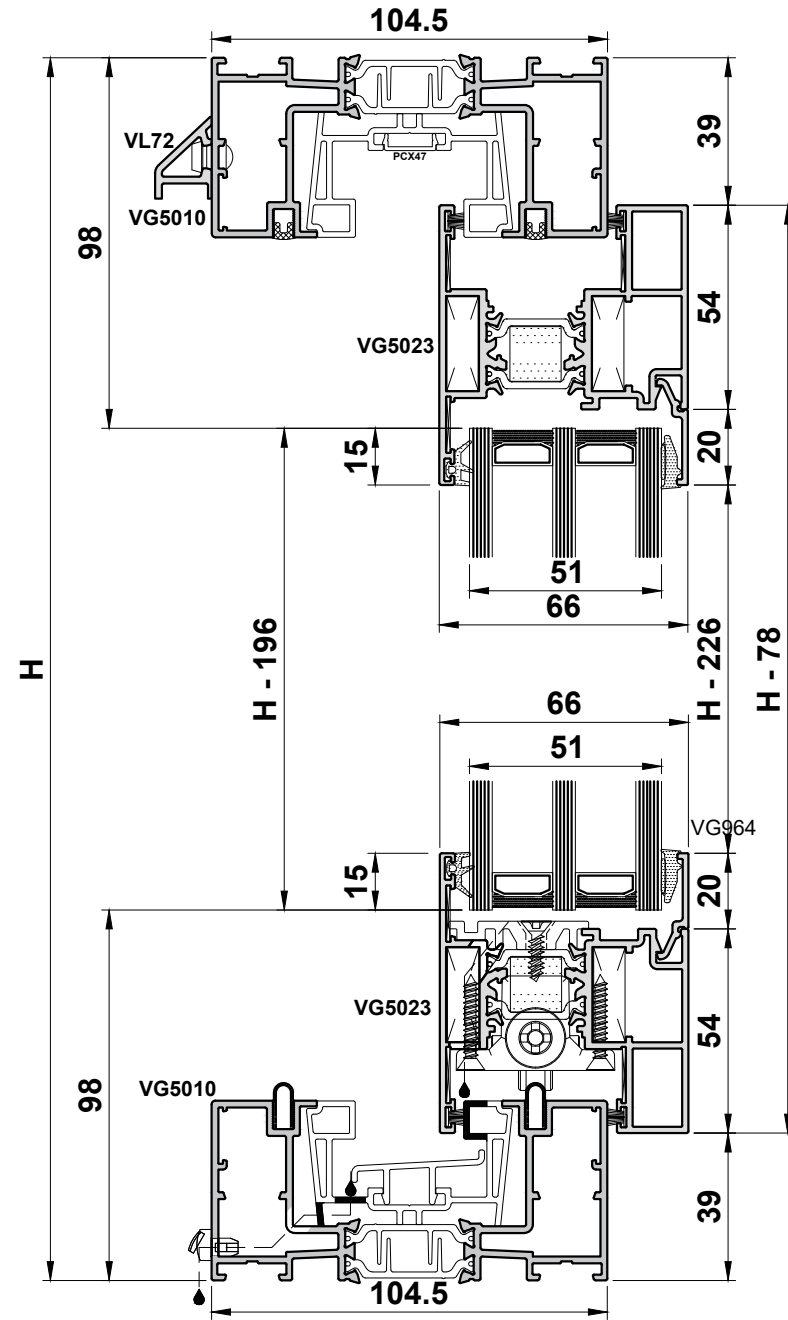
ACCESSORIES

ACGSL045		MAX 500 mm	Drainage Cap
ACVG5023		12	Sash Cleat
ACVG5024		4	Sash Cleat
ACVG5032		2	Interlock Plug
ACUN348		4	Buffer
ACVG5010		8	Outer Frame Cleats
ACVG920		32	Chevron
ACVG523		26	Lock Fixing Plates
ACVG529		1 Set of 4	Anti Lift Block/Guide
ACVG530		2 Pairs	Interlock Cover Cap
ACVG555		4	Adjustable Rollers
ACVG559		4	Bridge Packer
ACVS033		4H	Woolpile
ACVS034		8H + 4W	Woolpile
Ext. Glazing Gasket		4H + 2W - 1300	'E' Gasket
Int. Glazing Gasket		4H + 2W - 1300	Wedge Gasket

OPTIONAL

ACVL059		1 Pair	VL72 End Cap
ACVL061		(W÷300) + 2	VL72/VL76 Rivet

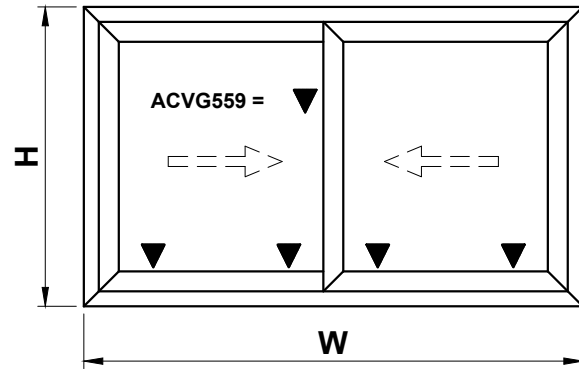
*See section E for lock & handle selection



Do Not Scale From This Drawing

Cutting Information - Sliding

IMPORTANT NOTE:
Maximum Sash Weights:
Sliding Sashes = 250kg



GLASS SIZE	
2x	(W÷2) - 124.5 H - 196

PROFILES

VG5010 (with VG5050)		2		W
VG5010 (with VG5050)		2		H
VG920		4		(W÷2) - 6.5
VG920		4		H - 78
VG530		2		H - 78
VG5051		2		H - 78
VG586		2		H - 78
BEAD		4		(W÷2) - 114.5
BEAD		4		H - 226
VG52		2		W - 95
VG52		4		H - 95
VG53		2		W - 95
VG7075		2		(W÷2) - 56.5

OPTIONAL

VL72		1		W - 9
VG5014		1		(W÷2) - 89
VG5014		1		H - 98

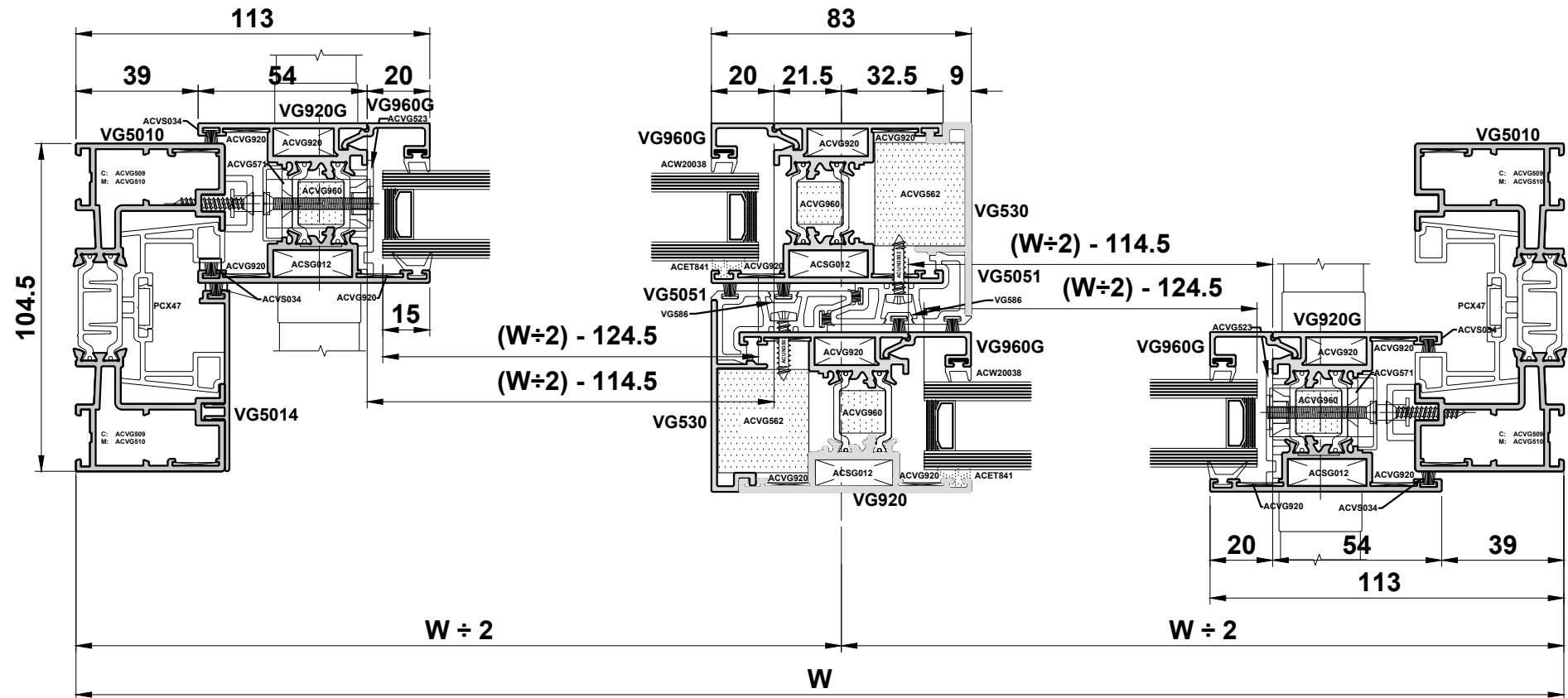
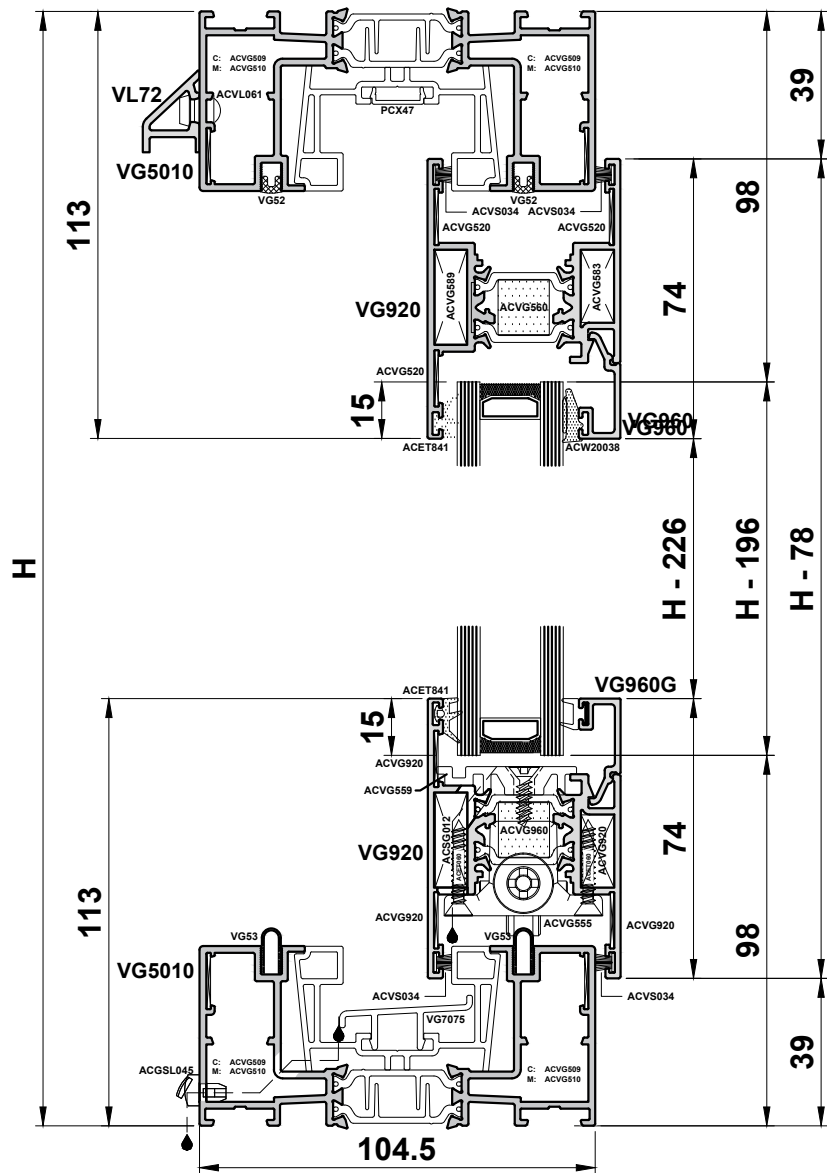
ACCESSORIES

ACGSL045		MAX 600 mm	Drainage Cap
ACVG589	16		Sash Cleat
ACVG5032	2		Interlock Plug
ACUN348	4		Buffer
ACVG5010	8		Outer Frame Cleats
ACVG920	32		Chevron
ACVG523	26		Lock Fixing Plates
ACVG529	1 Set of 4		Anti Lift Block/Guide
ACVG530	2 Pairs		Interlock Cover Cap
ACVG555	4		Adjustable Rollers
ACVG559	4		Bridge Packer
ACVS033	4H		Woolpile
ACVS034	8H + 4W		Woolpile
Ext. Glazing Gasket	4H + 2W - 1300		'E' Gasket
Int. Glazing Gasket	4H + 2W - 1300		Wedge Gasket

OPTIONAL

ACVL059	1 Pair	VL72 End Cap
ACVL061	(W÷300) + 2	VL72/VL76 Rivet

*See section E for lock & handle selection

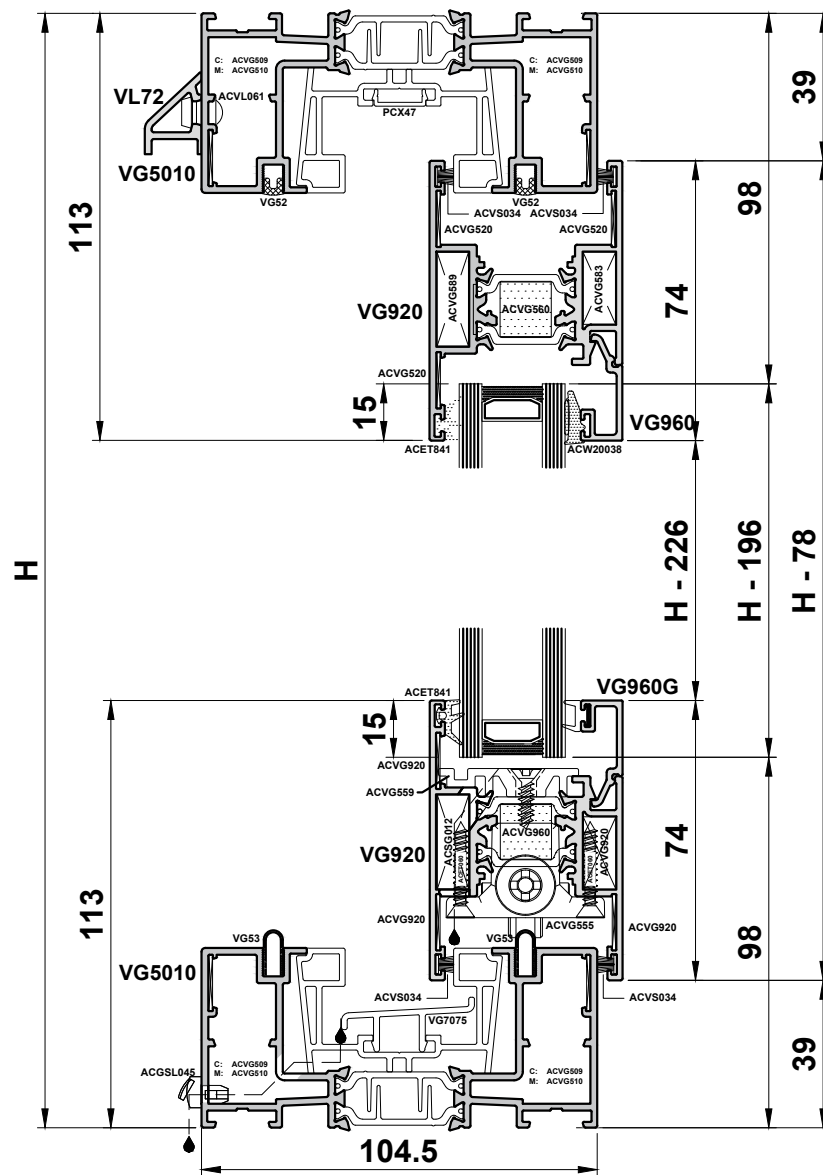


Do Not Scale From This Drawing

Cutting Information - Sliding with 20mm Interlock

IMPORTANT NOTE:

Maximum Sash Weights:
Sliding Sashes = 250kg



PROFILES

VG5010 (with VG5050)		2		W
VG5010 (with VG5050)		2		H
VG920		2		(W÷2) - 39
VG920		2		H - 78
BEAD		4		(W÷2) - 103
BEAD		2		H - 226
VG52		2		H - 95
VG52		2		W - 95
VG53		2		W - 95
VL72		1		W - 9
VG565/VG566*		2		H - 186
VG590		1		H - 78
VG592		1		H - 78
VG594		1		H - 226
VG596		2		H - 78
VG7075		2		(W÷2) - 56.5

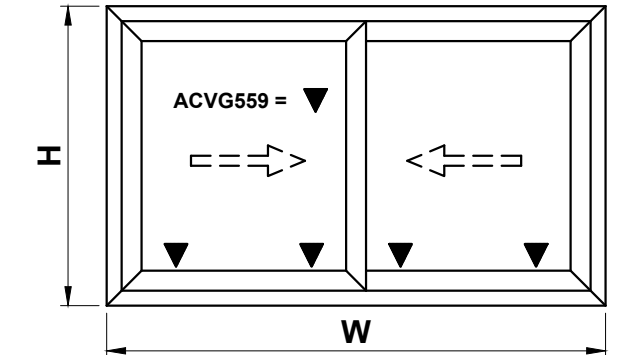
*We recommend to cut VG565/566 full height

ACCESSORIES

ACGSL045		MAX 800 mm	Drainage Cover Cap
ACSG012		8	Vent Cleats
ACUN348		2	Stoppers
ACVG5010		8	Outer Frame Cleats
ACVG920		20	Chevrons
ACVG523		26	Fixing Plates
ACVG529		2 Sets Of 4	Anti Lift Block/Guide
ACVG540		1	VG540 End Cap
ACVG545		2	Sash Guide
ACVG547		8	Fixing Bracket
ACVG555		4	Rollers
ACVG559		4	Bridge Packer
ACVG591		4	Interlock Cover Cap Kit
ACVG5032		2**	Slim Interlock Plug
ACVG593		4	End Pad

**For PAS 24, additional 4 x ACGV5032 required

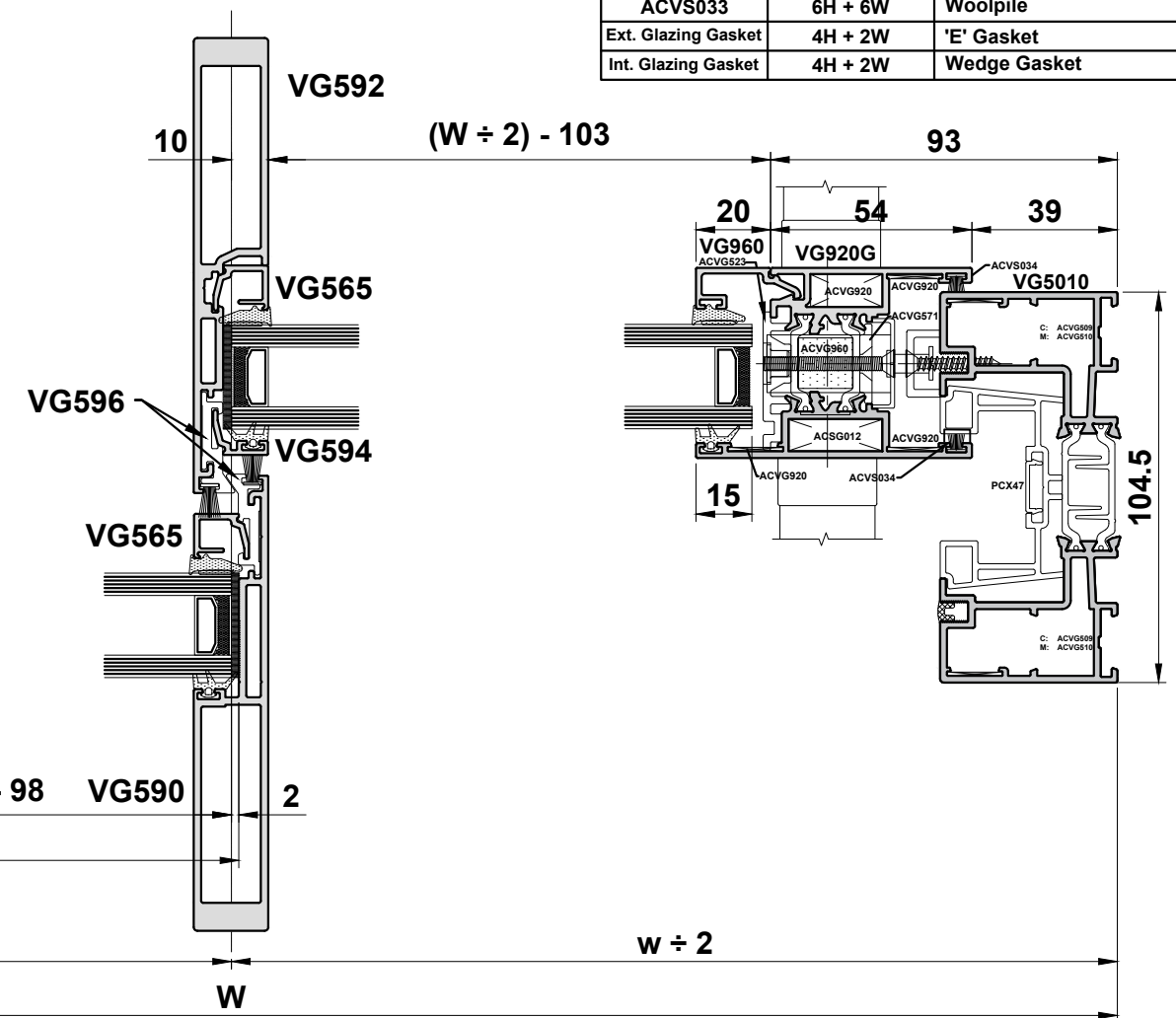
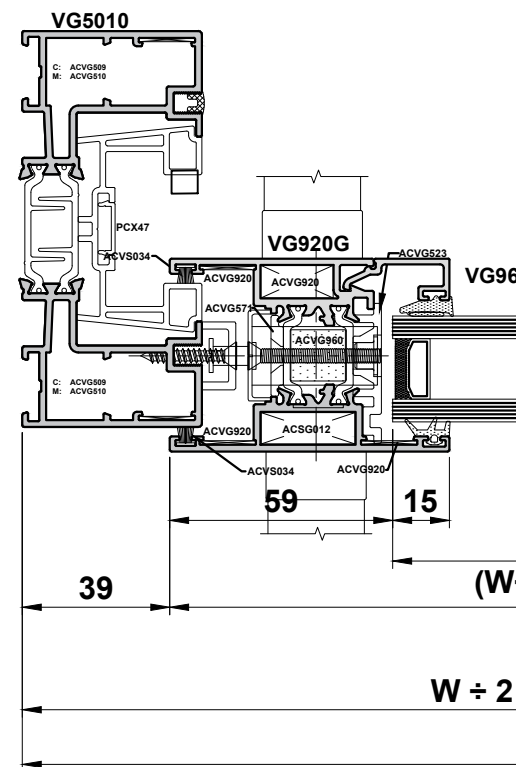
***See section E for lock & handle selection



ACCESSORIES

ACVG594	2	VG590 End Cap
ACVG595	2	VG592 End Cap
ACVG597	1 Pack Of 4	Interlock Security Device
ACVL059	2	End Caps VL72
ACVL061	W/300 + 2	Rivets VL72
ACVS033	6H + 6W	Woolpile
Ext. Glazing Gasket	4H + 2W	'E' Gasket
Int. Glazing Gasket	4H + 2W	Wedge Gasket

GLASS SIZE	
2x	(W÷2) - 98
	H - 196

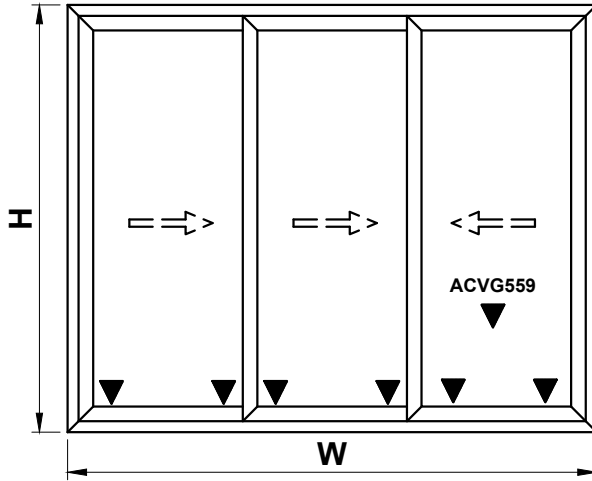


Do Not Scale From This Drawing

Cutting Information - Sliding

IMPORTANT NOTE:

Maximum Sash Weights:
Sliding Sashes = 250kg

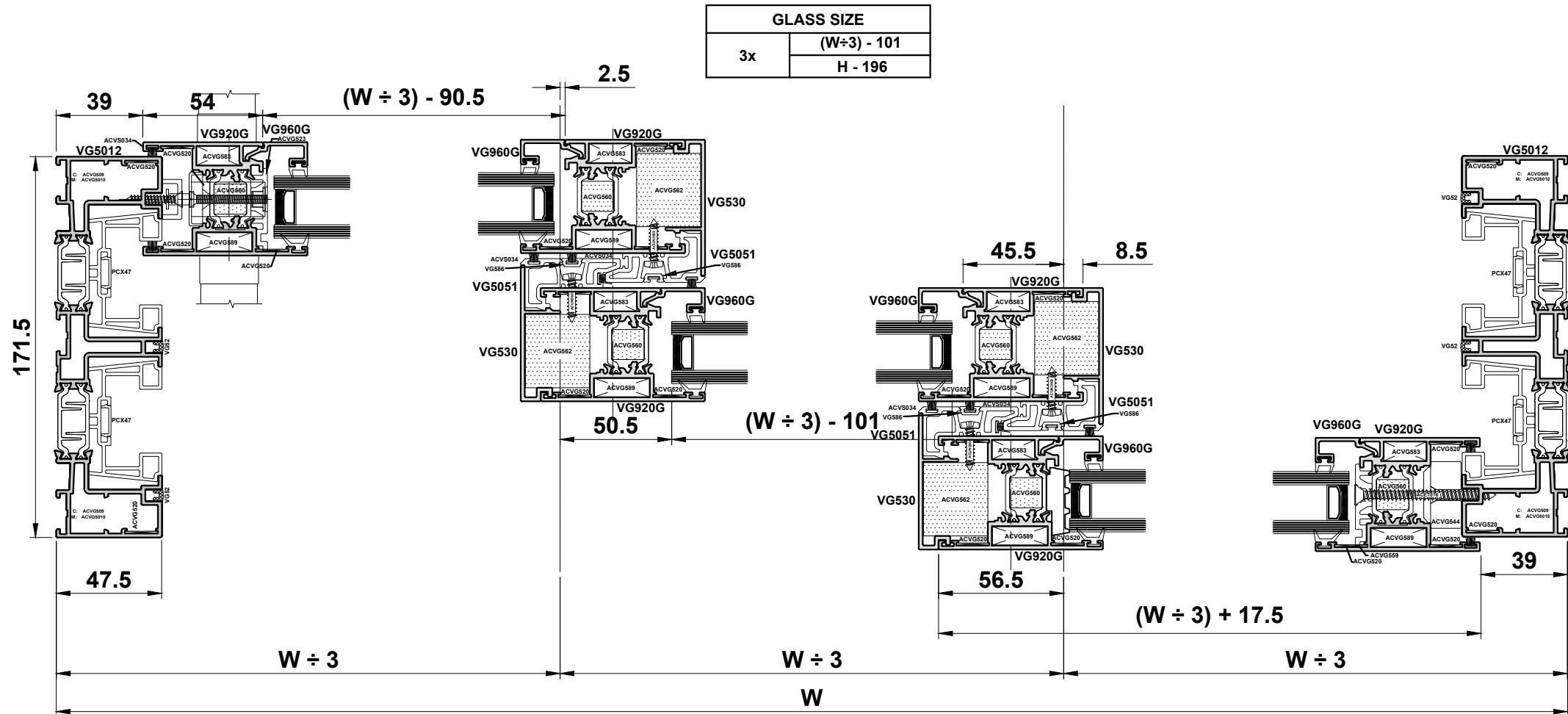
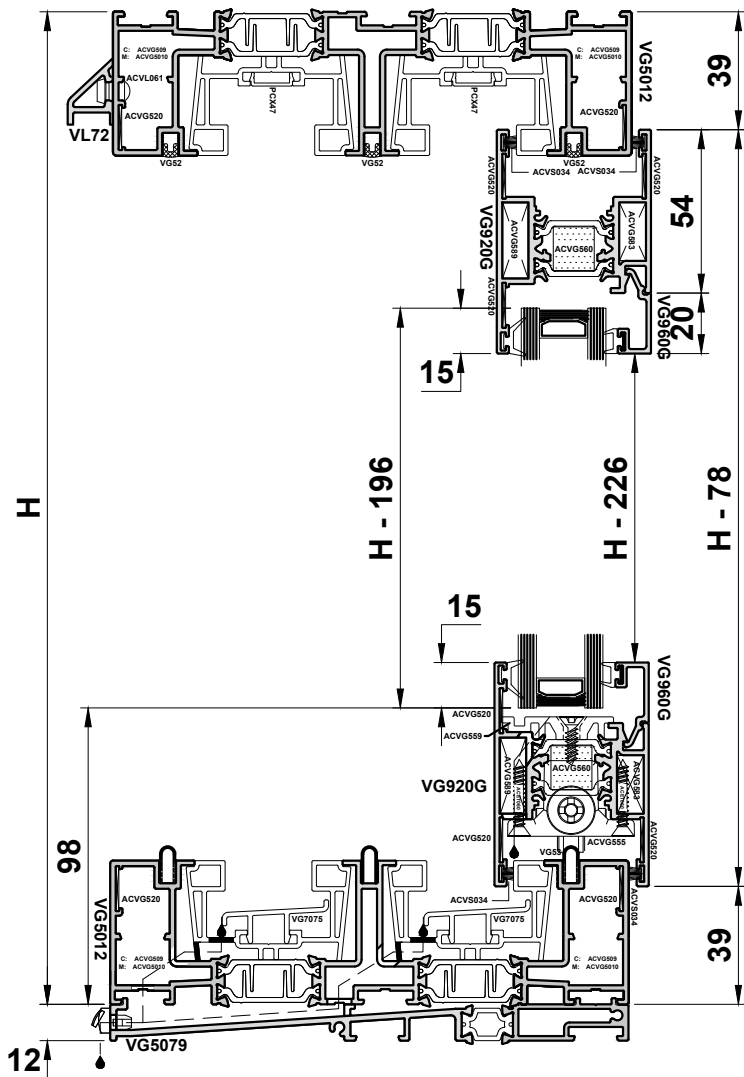


PROFILES

VG5012 (with VG5050)		2		W
VG5012 (with VG5050)		2		H
VG5079		1		W
VG920		6		(W÷3) + 17.5
VG920		6		H - 78
VG530		4		H - 78
VG5051		4		H - 78
VG586		4		H - 78
BEAD		6		(W÷3) - 90.5
BEAD		6		H - 226
VG52		3		W - 95
VG52		4		H - 95
VG53		3		W - 95
VG7075		4		(W÷3) - 32.5
VG7075		2		(W÷3) X2 - 80.5
VG7075		1		(W÷3) - 112
VL72		1		W - 9

ACCESSORIES

ACGSL045		MAX 600 mm	Drainage Cap
ACSG012	24	Sash Cleat	
ACUG830	4	Interlock Seal	
ACUN348	6	Buffer	
ACVG510	8	Outer Frame Cleats	
ACVG920	36	Chevron	
ACVG523	26	Lock Fixing Plates	
ACVG529	3 Set of 4	Anti Lift Block/Guide	
ACVG530	8	Interlock Cover Cap	
ACVG534	6+	Sash Drainage Spout	
ACVG555	6	Adjustable Rollers	
ACVG577	1 Pair	VG577 End Cap	
ACVG559	6	Bridge Packer	
ACVL059	1 Pair	VL72 End Cap	
ACVL061	W/300 + 2	VL72/VL76 Rivet	
ACVS033	12H + 12W	Woolpile	
ACVS034	2H	Woolpile	
Ext. Glazing Gasket	6H + 2W	'E' Gasket	
Int. Glazing Gasket	6H + 2W	Wedge Gasket	



GLASS SIZE	
3x	(W÷3) - 101
	H - 196

Do Not Scale From This Drawing